

Jin-Soo Kim
(jinsoo.kim@snu.ac.kr)

Systems Software &
Architecture Lab.
Seoul National University

Spring 2026

File Systems



File System Abstraction

■ File

- A named collection of related information that is recorded on persistent storage
- Each file has an associated inode number (internal file ID)
- Inodes are unique within a file system

■ Directory

- A logical group of files
- Hierarchical directory tree: directories can be placed within other directories
- A special file used to map a user-readable file name to its inode number:
a list of <file name, inode number>

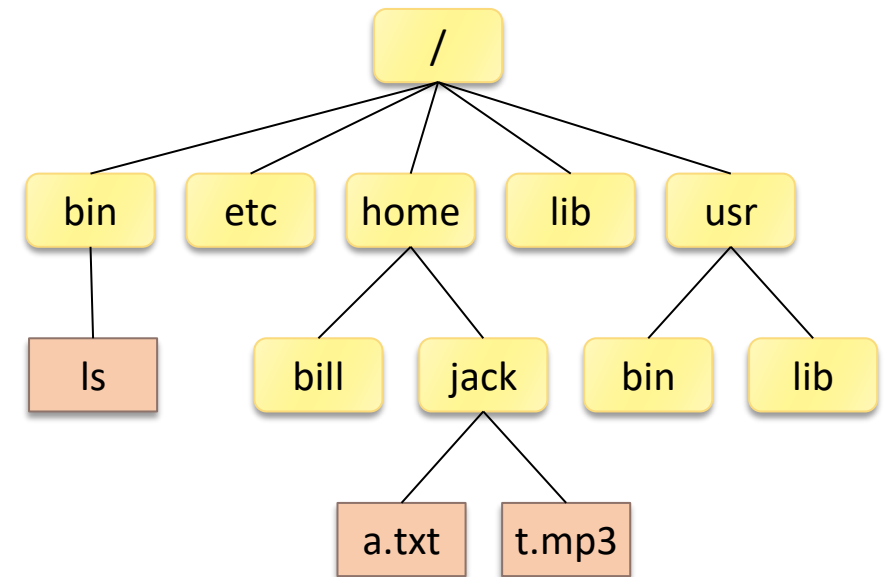

File System Components

- **File contents (data)**
 - A sequence of bytes
 - File systems normally do not care what they are
- **File attributes (metadata or inode)**
 - File size
 - Block locations
 - Owner & access control lists
 - Timestamps, ...
- **File name**
 - The full pathname from the root specifies a file
 - e.g., `open("/home/jack/t.mp3", O_RDONLY);`

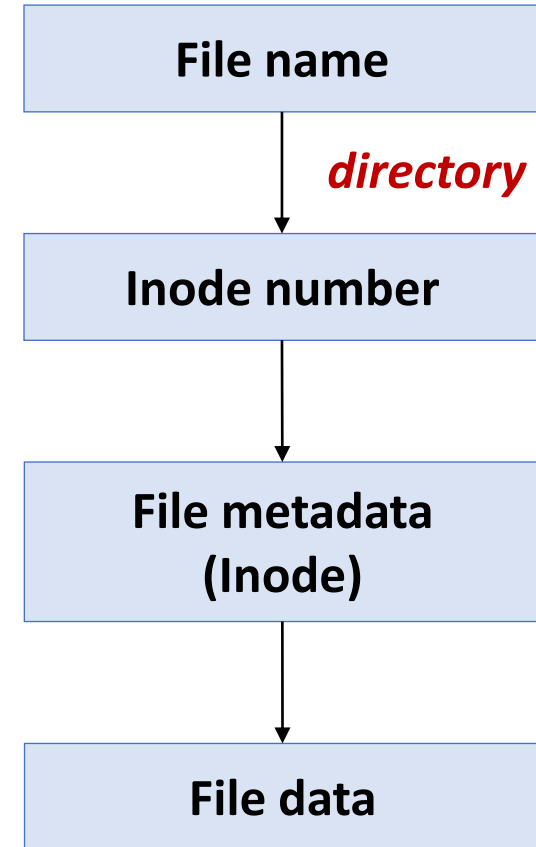

File System Layers

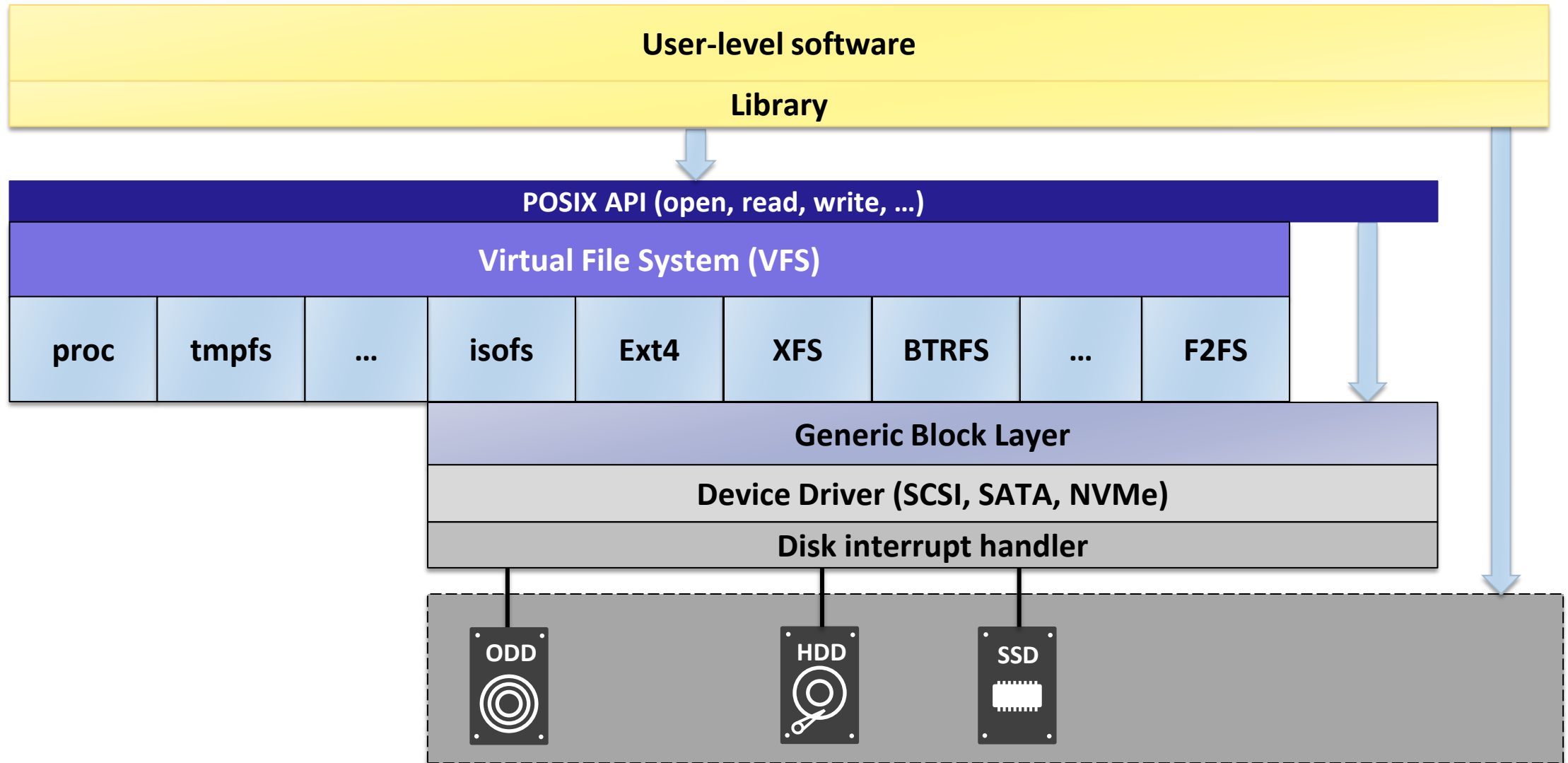

File Interfaces

- POSIX operations

open	Create a file or open an existing file
close	Close a file
read	Read data from a file
write	Write data to a file
lseek	Reposition read/write file offset
stat	Get file status
fsync	Synchronize a file's in-core state with storage device
link	Make a new name for a file
unlink	Delete a name and possibly the file it refers to
rename	Change the name or location of a file
chown	Change ownership of a file
chmod	Change permissions of a file
flock	Apply or remove an advisory lock on an open file

POSIX Inode

- Inode number
- File type: regular, directory, char/block dev, fifo, symbolic link, ...
- Device ID containing the file
- User ID and group ID of the owner
- Access permission: *rw*x for owner(*u*), group(*g*), and others(*o*)
- Number of hard links
- File size in bytes
- Number of 512B blocks allocated
- Timestamps: time of last _____ (*atime*), time of last modification (*mtime*), time of last _____ (*ctime*)

File System Issues

- **Block allocation**
 - Data blocks for each file or directory
 - Metadata blocks for files and directories
 - Free space management
- **Block indexing**
 - $\langle \text{inode \#, offset} \rangle \rightarrow \text{block \#}$
- **Directory indexing for fast lookup**
 - $\text{" /path/name/to/file" } \rightarrow \text{inode \#}$
- **Metadata consistency on crash**
 - Journaling



Ensuring Persistence

- File system buffers writes into memory (“page cache”)
 - Write buffering improves performance
 - Up to 30 seconds in Linux
 - `sync()`: flushes all pending filesystem metadata and data
 - `fsync()`: flushes all dirty data and metadata associated with the file
 - `fdatasync()`: does not flush modified metadata unless it is needed in order to allow a subsequent data retrieval to be correctly handled (e.g., change to file size)

```
int fd = open("foo", O_CREAT | O_WRONLY | O_TRUNC);
int rc = write(fd, buffer, size);
rc = fsync(fd);
close(fd);
```

Crash Consistency

- File system may perform several disk writes to complete a single system call
 - e.g., `creat()`, `write()`, `unlink()`, `rename()`, ...
 - But, disk only guarantees atomicity of a single sector write
- If file system is interrupted between writes, the on-disk structure may be left in an inconsistent state
 - Power loss
 - System crash (kernel panic)
 - Transient hardware malfunctioning
- We want to move file system from one consistent state to another atomically

Journaling (Write-ahead Logging)

- A well-known technique for database transactions
 - Record a log, or journal, of changes made to on-disk data structures to a separate location (“journaling area”)
 - Write updates to their final locations (“checkpointing”) only after the journal is safely written to disk
- If a crash occurs:
 - Discard the journal if the journal write is not committed
 - Otherwise, redo the updates based on the journal data
- Fast as it requires to scan only the journaling area
- Used in modern file systems:
Linux Ext3/4, ReiserFS, IBM JFS, SGI XFS, Windows NTFS, ...

File System Semantics

- What if two processes write to the same file concurrently?
- What if a file is modified while the other process is reading it?
- What if a file is deleted while the other process still uses it?
- What if the permission of a file is changed while the other process still uses it?
- What if a process tries to write data into the location beyond the file size?
- What if the power is lost during `rename("a", "b")`?

A Fast File System for UNIX

(M. McKusick et al., ACM TOCS 1984)

The Original Unix FS

- First Unix file system developed by Ken Thompson

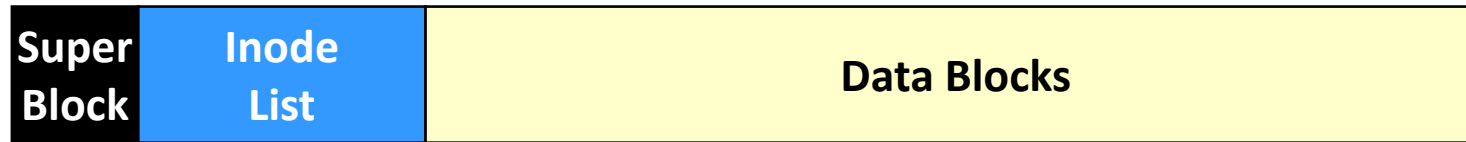

- **Superblock**
 - Basic information of the file system
 - Head of freelists of Inodes and data blocks
- **Inode list**
 - Referenced by index into the inode list
 - All inodes are the same size
- **Data blocks**
 - A data block belongs to only one file

Problems

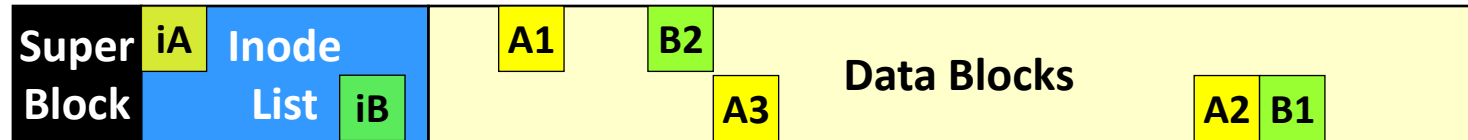

- Files are fragmented as the file system “ages”
 - Blocks are allocated randomly over the disk
- Inodes are allocated far from blocks
 - Traversing pathnames or manipulating files and directories requires long seeks between inodes and data blocks
- Files in a directory are typically not allocated in consecutive inode slots
- The small block size: 512 bytes

FFS

- The original Unix file system (70's) was very simple and straightforwardly implemented
 - But, achieved only 2% of the maximum disk bandwidth
- BSD Unix folks redesigned file system called FFS
 - McKusick, Joy, Leffler, and Fabry (80's)
 - Keep the same interface, but change the internal implementation
- The basic idea is _____
 - Place related things on nearby cylinders to reduce seeks
 - Improved disk utilization, decreased response time

Bitmaps

- Use bitmaps instead of free lists

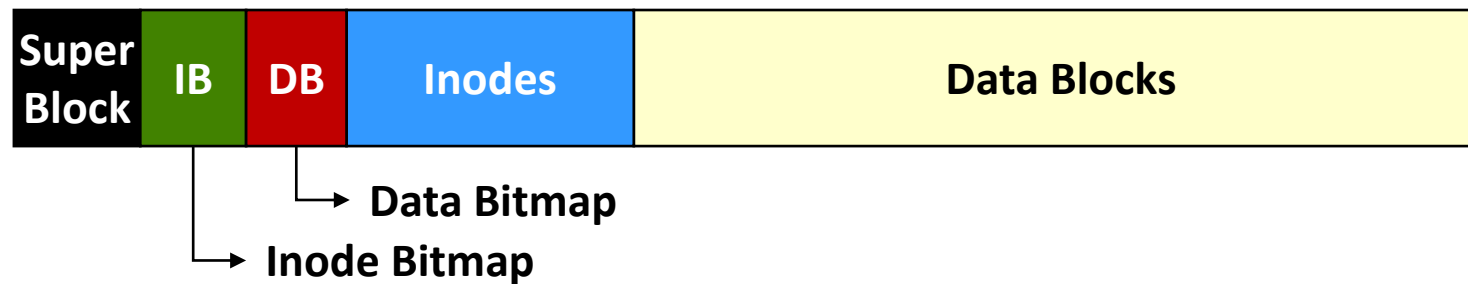

- Each bit represents whether the corresponding inode (or data block) is free or in use
- **What's good?**

Cylinder Groups

- Divides the disk into a number of cylinder groups

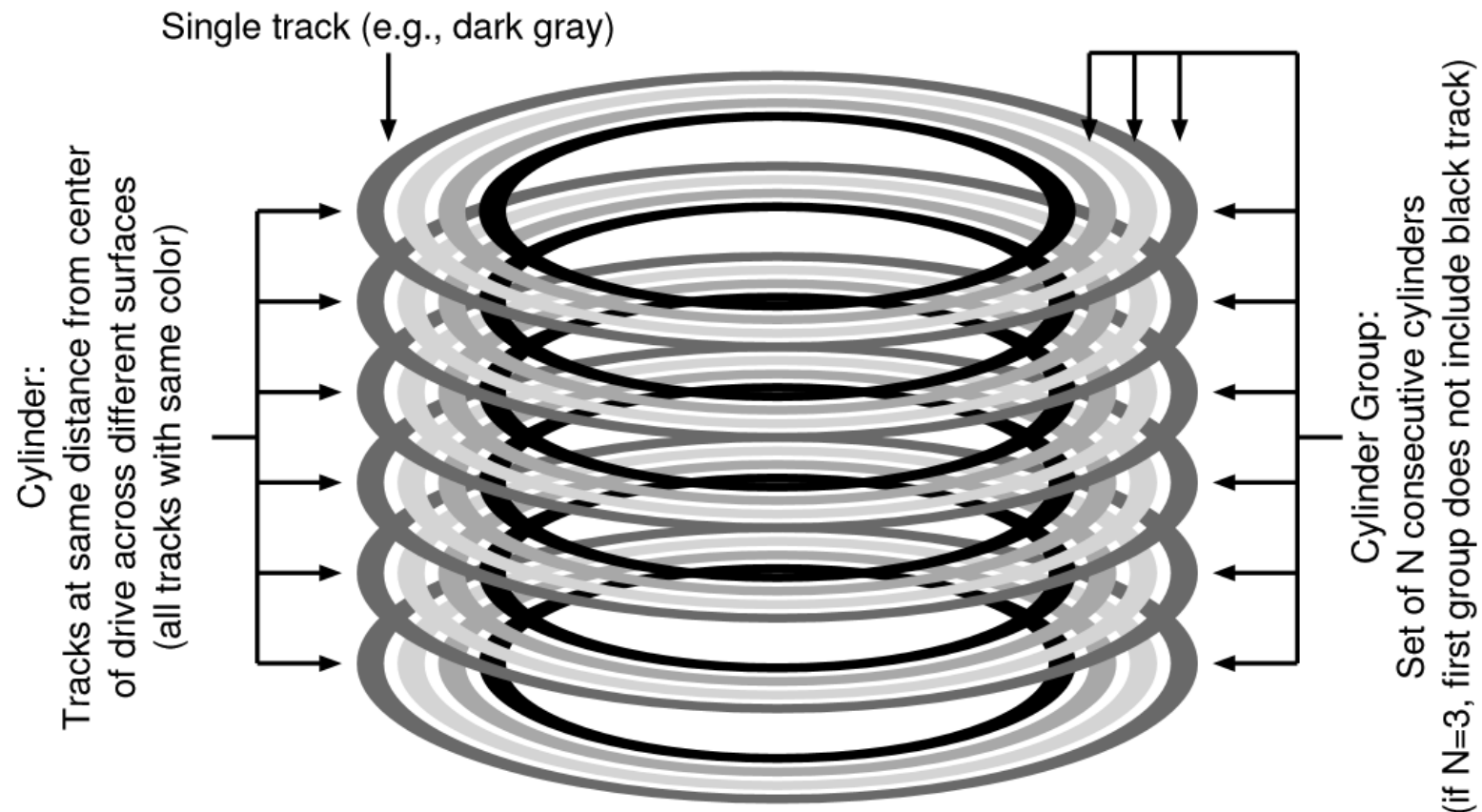

On-Disk Layout

- Put all the structures within each cylinder group
 - Block size is increased to 4KB to improve throughput
 - Superblock (S) is replicated for reliability reasons
 - Modern drives do not export disk geometry information
 - Modern file systems organize the drive into “block groups” (e.g., Linux Ext2/3/4)

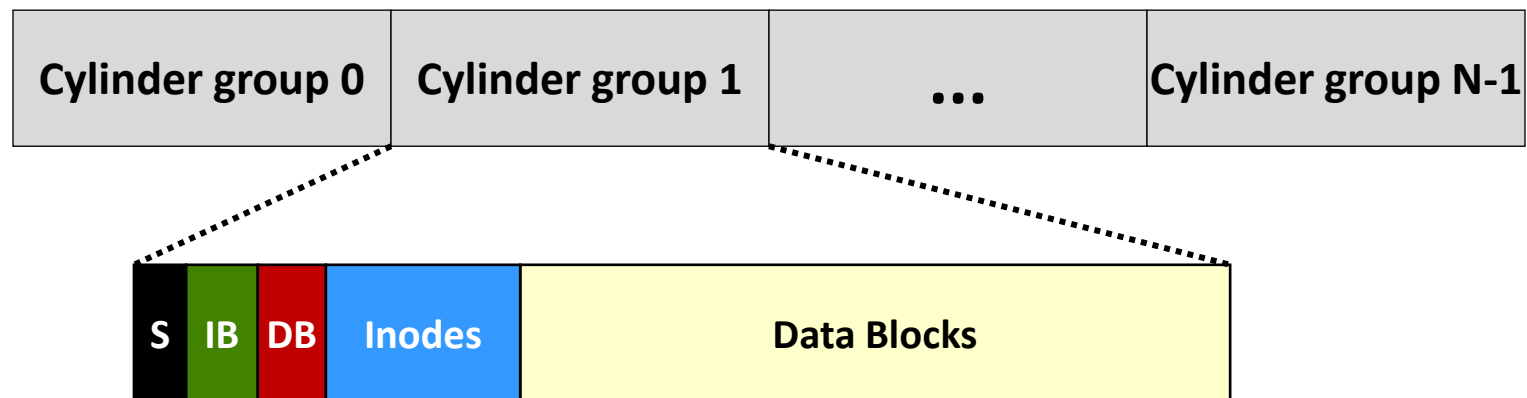

Allocation Policies

- Keep related stuff together
- Balance directories across groups
 - Allocate directory blocks and its inode in the cylinder group with a low number of allocated directories and a high number of free inodes
- Files in a directory are often accessed together
 - Place all files that are in the same directory in the cylinder group of the directory
 - Allocate data blocks of a file in the same group as its inode
 - Data blocks of a large file are partitioned into chunks and distributed over multiple cylinder groups

Other Features

- **Fragments to reduce internal fragmentation**
 - Each block can be broken optionally into 2, 4, or 8 fragments
 - The block map manages the space at the fragment level
- **File system parameterization**
 - Make the next block come into position under the disk head by skipping some blocks
- **Free space reserve**
- **Long file names**
- **Atomic rename**
- **Symbolic links**

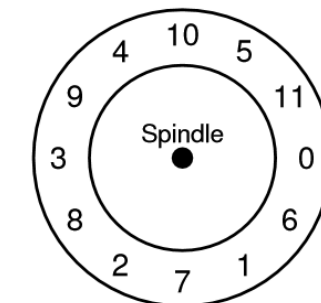
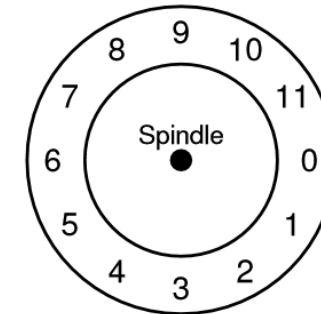

Summary

- **First disk-aware file system**
 - Cylinder groups
 - Bitmaps
 - Replicated superblocks
 - Large blocks
 - Smart allocation policies
- **FFS achieves 14% ~ 47% of the disk bandwidth**
 - The throughput deteriorates to about half when the file system is full
- **FFS inspired modern file systems including Ext2/3/4**

Ext4 File System

Ext2/3/4

- Evolved from Minix filesystem
 - Maximum file size: 64MB (16-bit block addresses)
 - Directory: fixed-size entries, file name up to 14 chars
- Virtual file system (VFS) added
- Extended filesystem (Ext), Linux 0.96c, 1992
- Ext2, Linux 0.99.7, 1993
- Ext3, Linux 2.4.15, 2001
- Ext4, Linux 2.6.19, 2006
 - Default file system for many Linux distributions and ~~Android-based smartphones~~

Ext4 Features

- Scalability
 - Support volume sizes up to 1EB
 - Support file sizes up to 16TB
- Extents-based mapping
- Flex block group
- Delayed allocation
- Multi-block allocator
- Directory indexing with Htree (since Ext3)
- Journaling for file system consistency (since Ext3)

Ext4 Inode

- File metadata (256 bytes/inode by default)
- Pointers for data blocks or extents

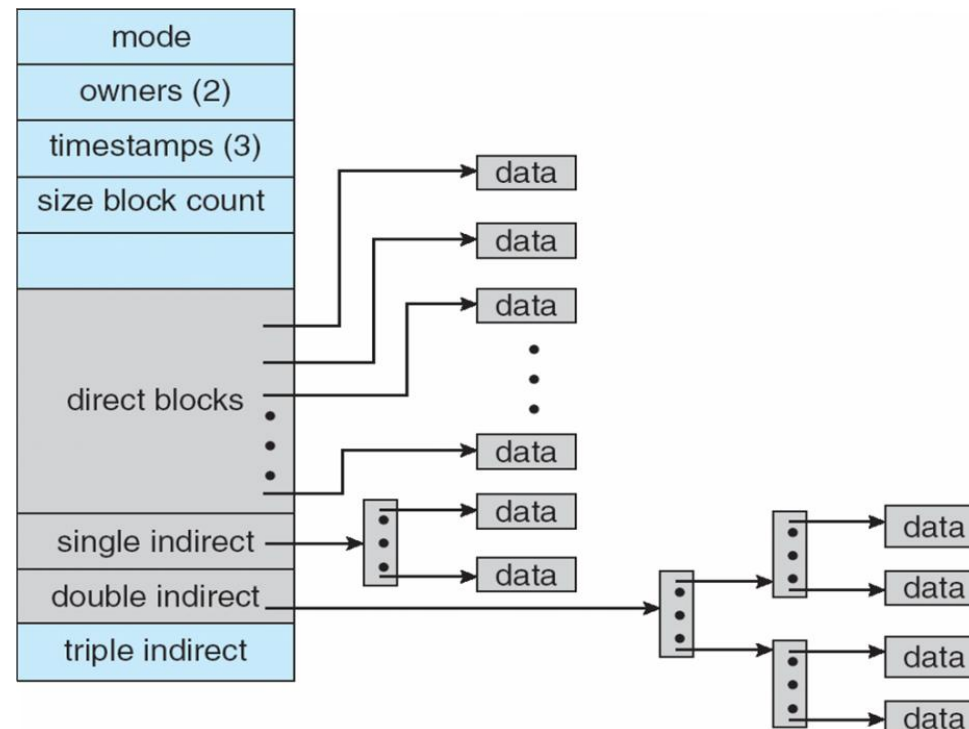

Ext4 On-disk Layout

- Block group
 - Similar to the cylinder group in FFS
 - All the block groups have the same size and are stored sequentially

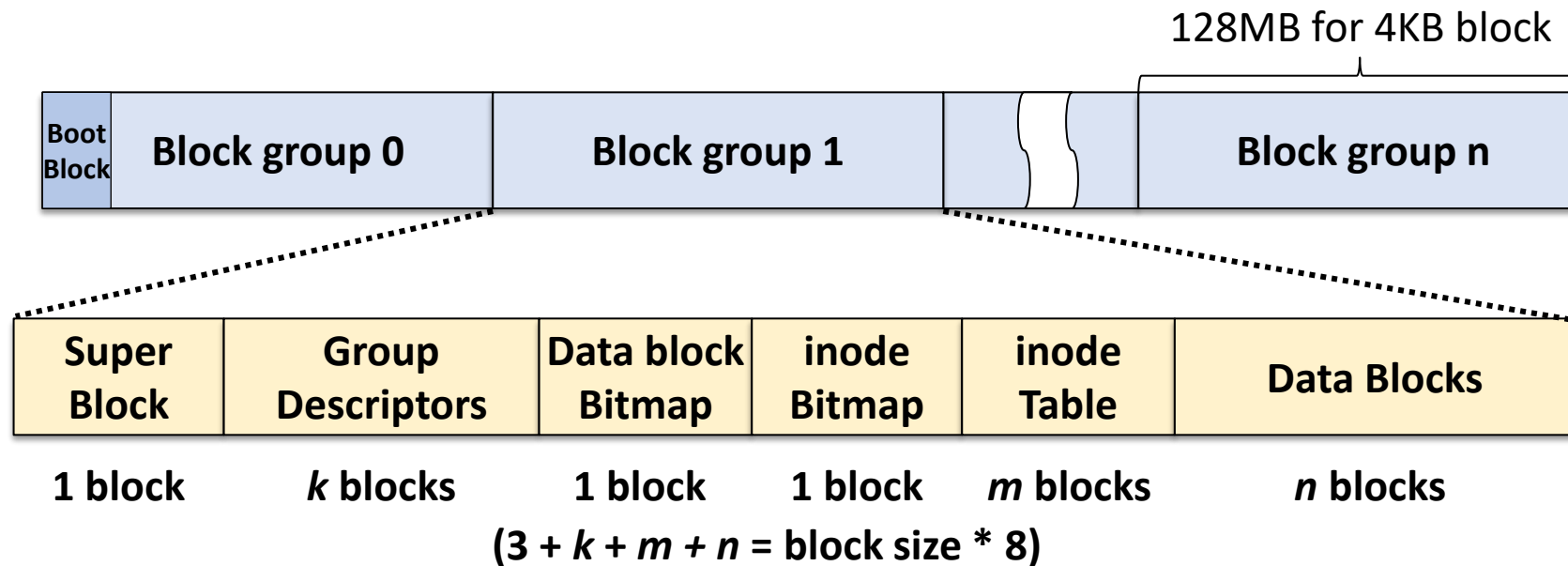

Ext4 Block Group

- **Superblock: file system metadata**
 - Total number of inodes
 - File system size in blocks
 - Free blocks / inodes counter
 - Number of blocks / inodes per group
 - Block size, ...
- **Group descriptor**
 - Number of free blocks / inodes / directories
 - Block number of block / inode bitmap, etc.
- **Both superblock and group descriptor are duplicated in other block groups**

Ext4 Extents

- Extent <offset, length, physical block>:
 - A single descriptor for a range of contiguous blocks
 - 32-bit logical block number (offset): file size up to 16TB
 - 48-bit physical block number: up to 1EB filesystem
 - 15-bit length: Max 128MB contiguous blocks
- An efficient way to represent large files
- Prevent file fragmentation
- Less metadata information to change on file deletion

Ext4 Extents Tree

- Up to four extents in the inode. Otherwise, extents tree is used.

- **Extent header**

- # valid entries
- # entries / node
- Tree depth
- Magic number

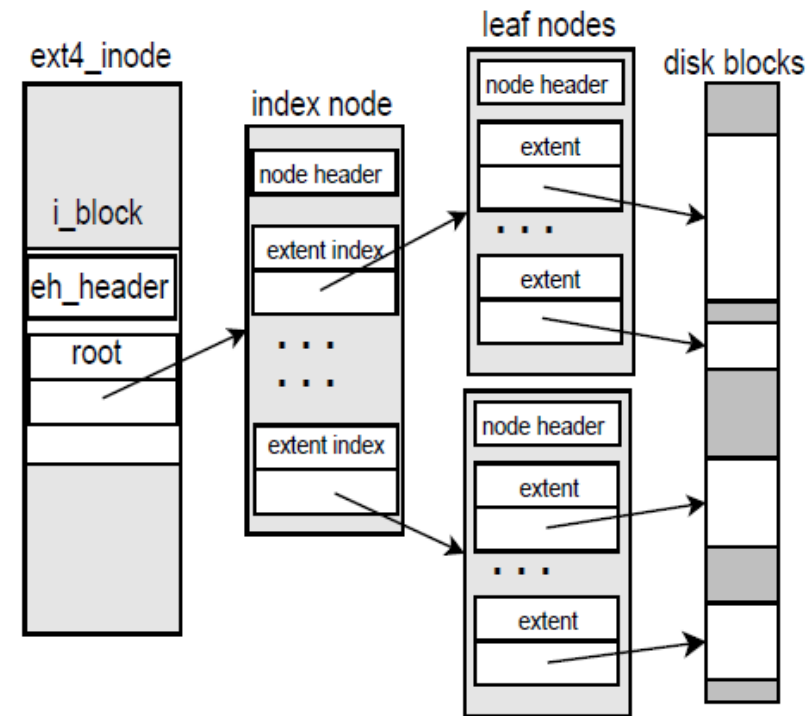

Ext4 Flex Block Groups

- Why?

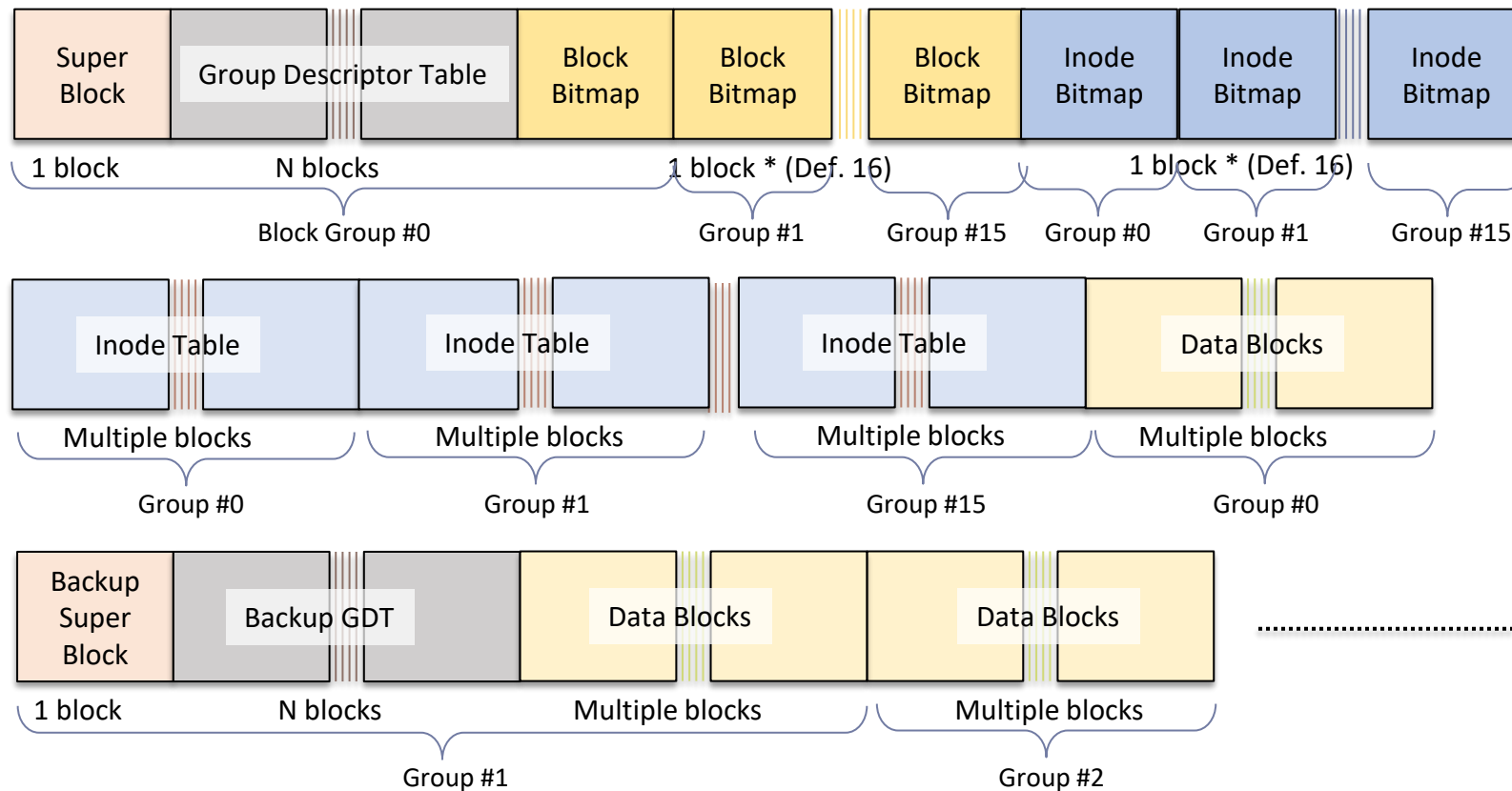

Ext4 Delayed Allocation

- Blocks allocations postponed to page flush time, rather than during the `write()` operation
 - *What's good?*

Ext4 Multi-block Allocator

- Ext3 allocates one block at a time
 - Inefficient for larger I/Os
- An entire extent, containing multiple contiguous blocks, is allocated at once
 - Reduce fragmentation
 - Reduce extent metadata
 - Eliminate multiple calls and reduce CPU utilization
- Stripe size aligned allocations
- Pack small files together and avoid fragmentation of free space (“per-cpu locality group”)

Ext4 Directory Indexing

- Htree-based directory
 - 32-bit hashes for keys
 - Each key refers to a range of entries in a leaf block
 - High fanout factor (over 500 for 4KB block)
 - Constant depth (one or two levels)
 - Leaf blocks are identical to old-style directory blocks

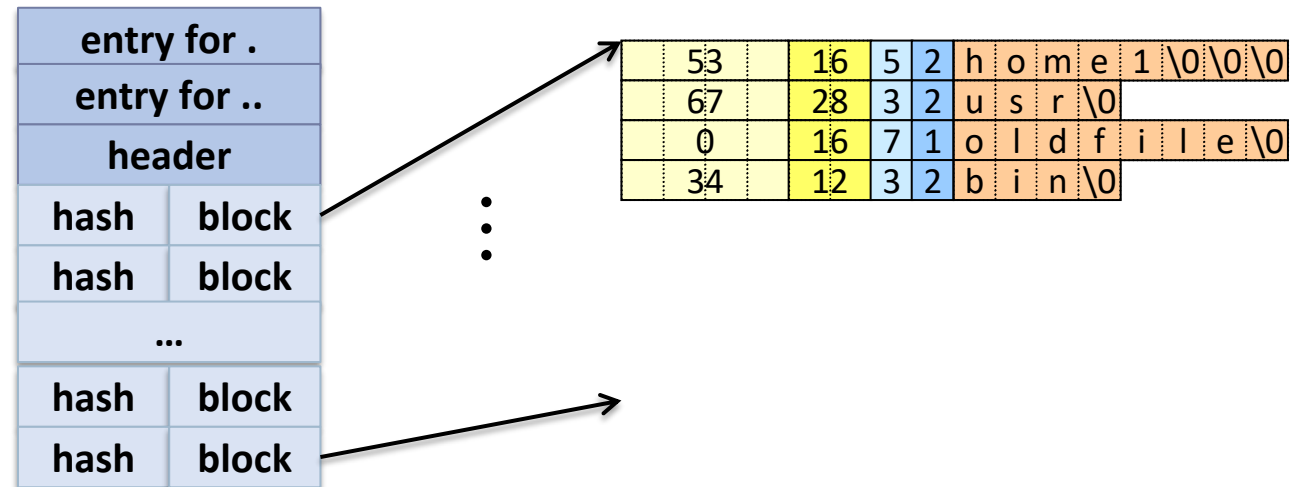

Ext4 Journaling

Journaling modes

