

Jin-Soo Kim  
([jinsoo.kim@snu.ac.kr](mailto:jinsoo.kim@snu.ac.kr))

Systems Software &  
Architecture Lab.

Seoul National University

Spring 2026

# Storage



# Hard Disk Drives (HDDs)

# The First HDD

- IBM 305 RAMAC (1956)
  - First commercially produced hard disk drive
  - 5 MB capacity, 50 platters each 24” in diameter, \$10,000/MB



<https://medium.com/@tonyjum/future-of-data-storage-a65dcof3e40>, <https://courses.engr.illinois.edu/cs241/sp2012/lectures/38-disk.pptx>

# Anatomy of an HDD

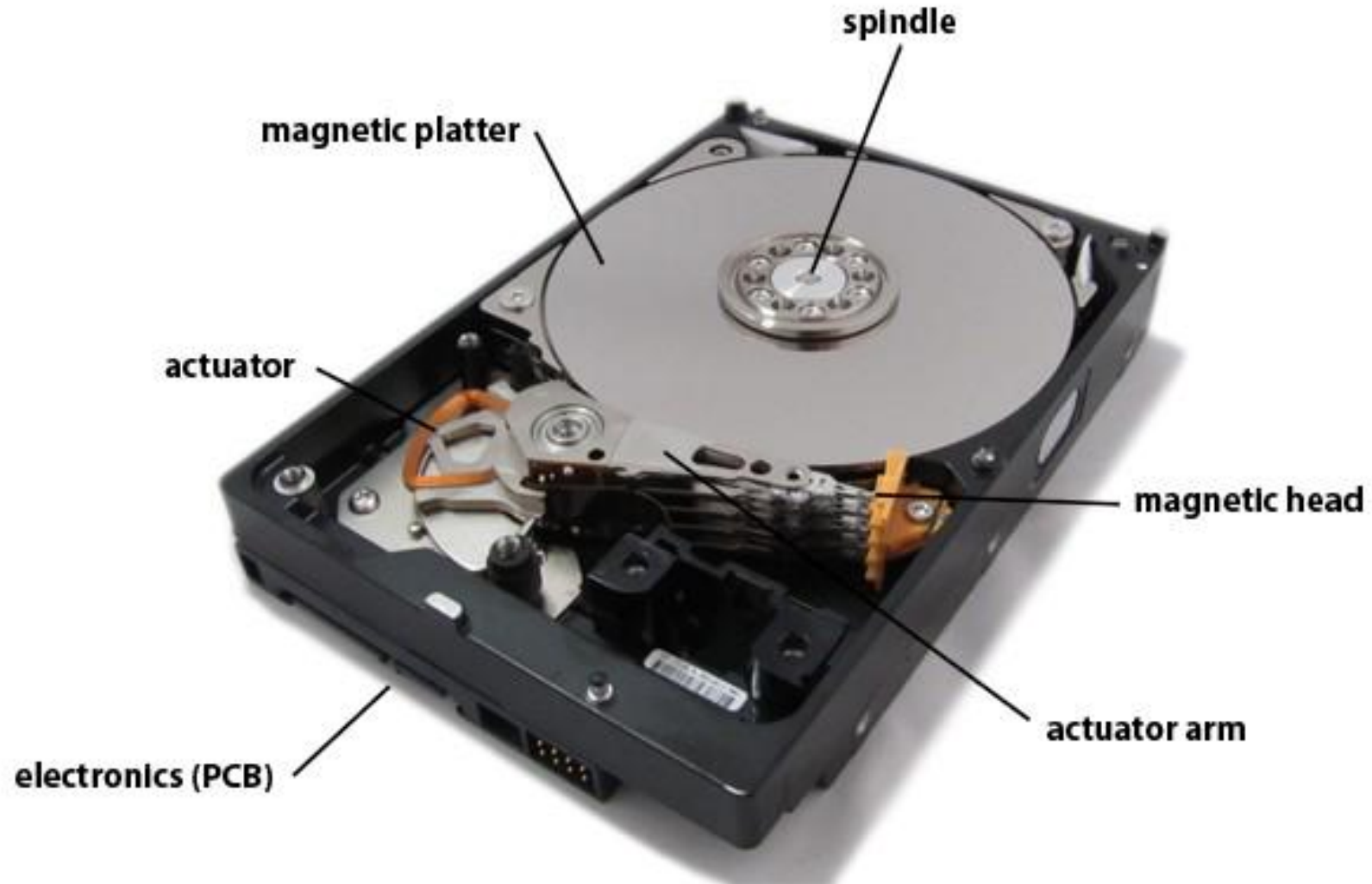

# Physical Drive Geometry

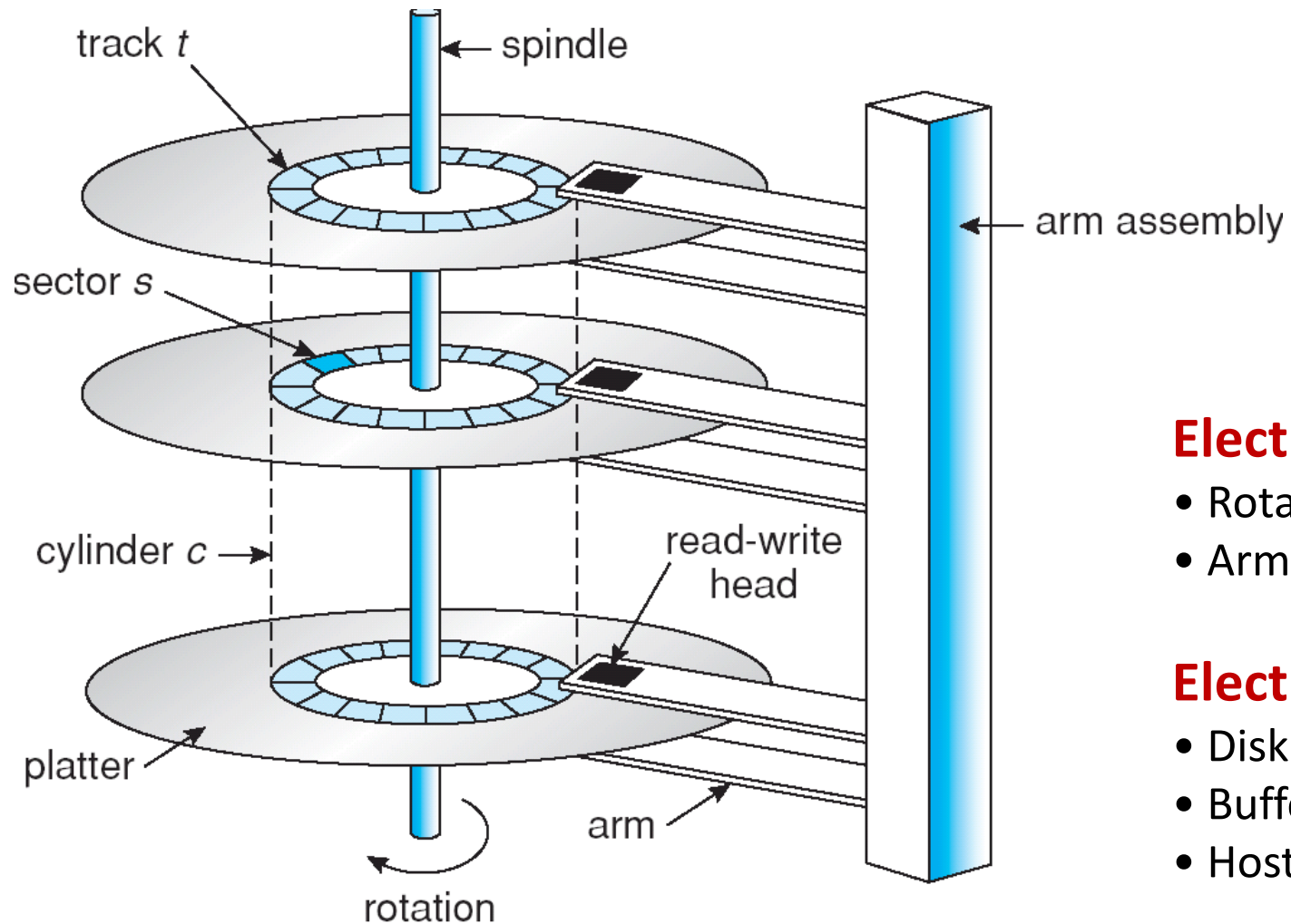

## Electromechanical

- Rotating disks
- Arm assembly

## Electronics

- Disk controller
- Buffer
- Host interface

# Interfacing with HDDs

- CHS (Cylinder-Head-Sector) scheme
  - The OS needs to know all disk “geometry” parameters
  - Modern disks are more complicated:  
Sector remapping, ZBR (Zone Bit Recording)
  - Can’t be generalized to other devices (e.g., tapes, networked storage)
- Logical block addressing (LBA) scheme
  - First introduced in SCSI
  - Disk is abstracted as a logical array of blocks  $[0, \dots, N-1]$
  - Disk maps an LBA to its physical location
  - Physical parameters of a disk are hidden from OS
  - 48-bit address with a release of ATA-6 in 2003

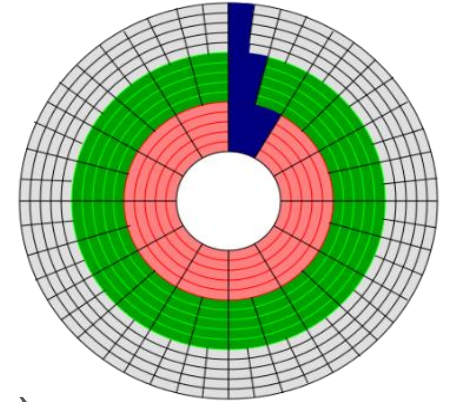

# HDD Performance Factors

- **Seek time ( $T_{seek}$ )**
  - Moving the disk arm to the correct cylinder
  - Depends on the cylinder distance (not purely linear cost)
  - Average seek time is roughly one-third of the full seek time
- **Rotational delay ( $T_{rotation}$ )**
  - Waiting for the sector to rotate under head
  - Depends on rotations per minute (RPM)
  - 5400, 7200 RPM common, 10K or 15K RPM for servers
- **Transfer time ( $T_{transfer}$ )**
  - Transferring data from surface into disk controller, sending it back to the host

# SATA NCQ

- Enqueue up to 32 commands in the drive
- Process them in an out-of-order fashion

## Native Command Queuing

Requested Read: A, B, C, D  
NCQ Reordered Read: B, D, A, C

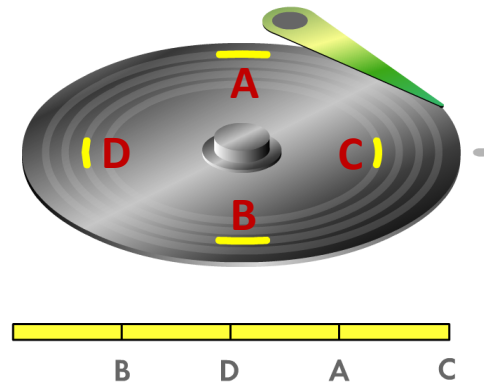

**Complete**  
(1.25 revolutions)

## Legacy Command Non-Queued

Requested Read: A, B, C, D  
Non-reordered Read: A, B, C, D

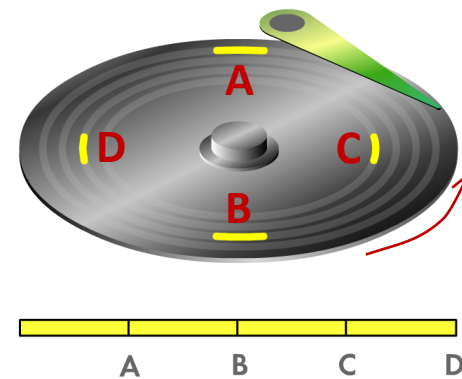

**Complete**  
(2.75 revolutions)

# SMR Disks

## ■ Shingled Magnetic Recording

- Recording heads are wider than reading heads
- Write new tracks that overlap part of the previously written magnetic track
- Higher storage capacity compared to CMR

## ■ Command interface

- Sequential zones (+ conventional zones)
- SCSI ZBC (Zoned Block Commands)
- ATA ZAC (Zoned Device ATA Command Set)
- Report Zones, Reset Zone Write Pointer, Open Zone, Close Zone, Finish Zone

## ■ Device-managed vs. Host-managed vs. Host-aware

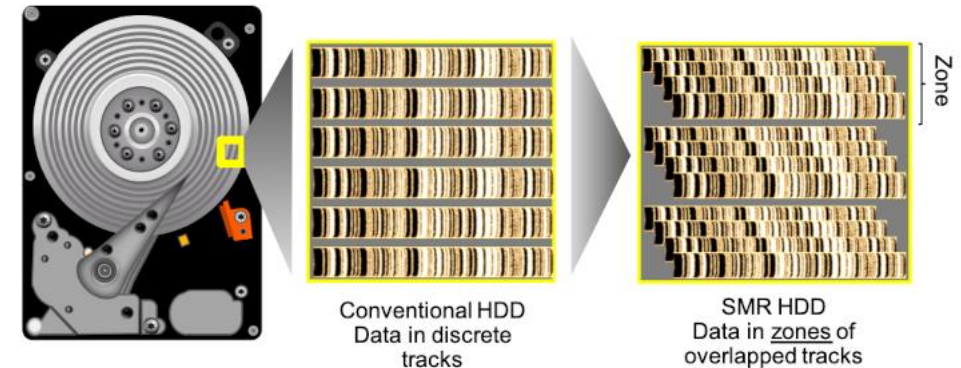

# Solid-State Drives (SSDs)

# A Quest for Non-Volatile Storage

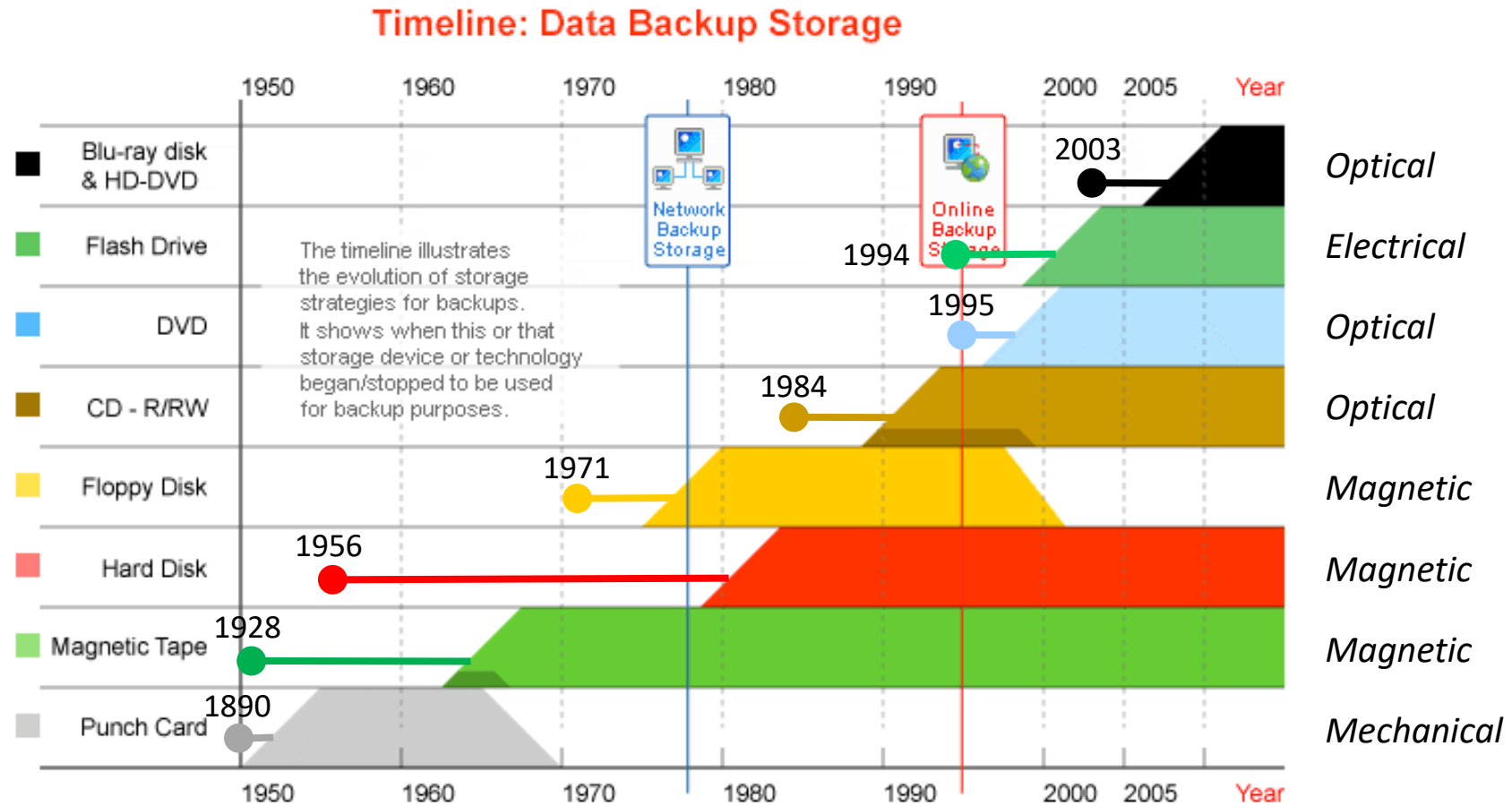

# Anatomy of an SSD

- Samsung 850 Evo

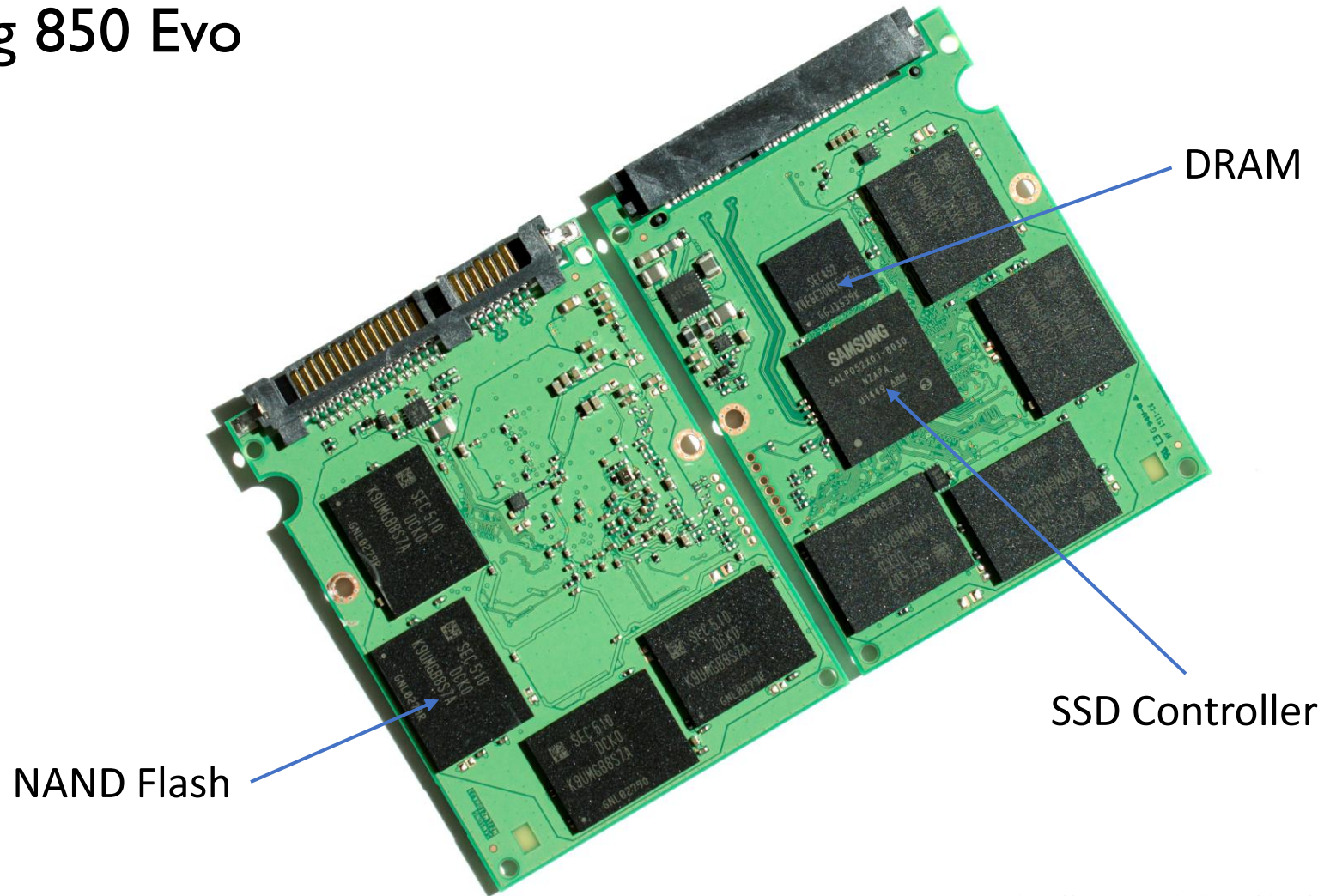

# SSD Internals

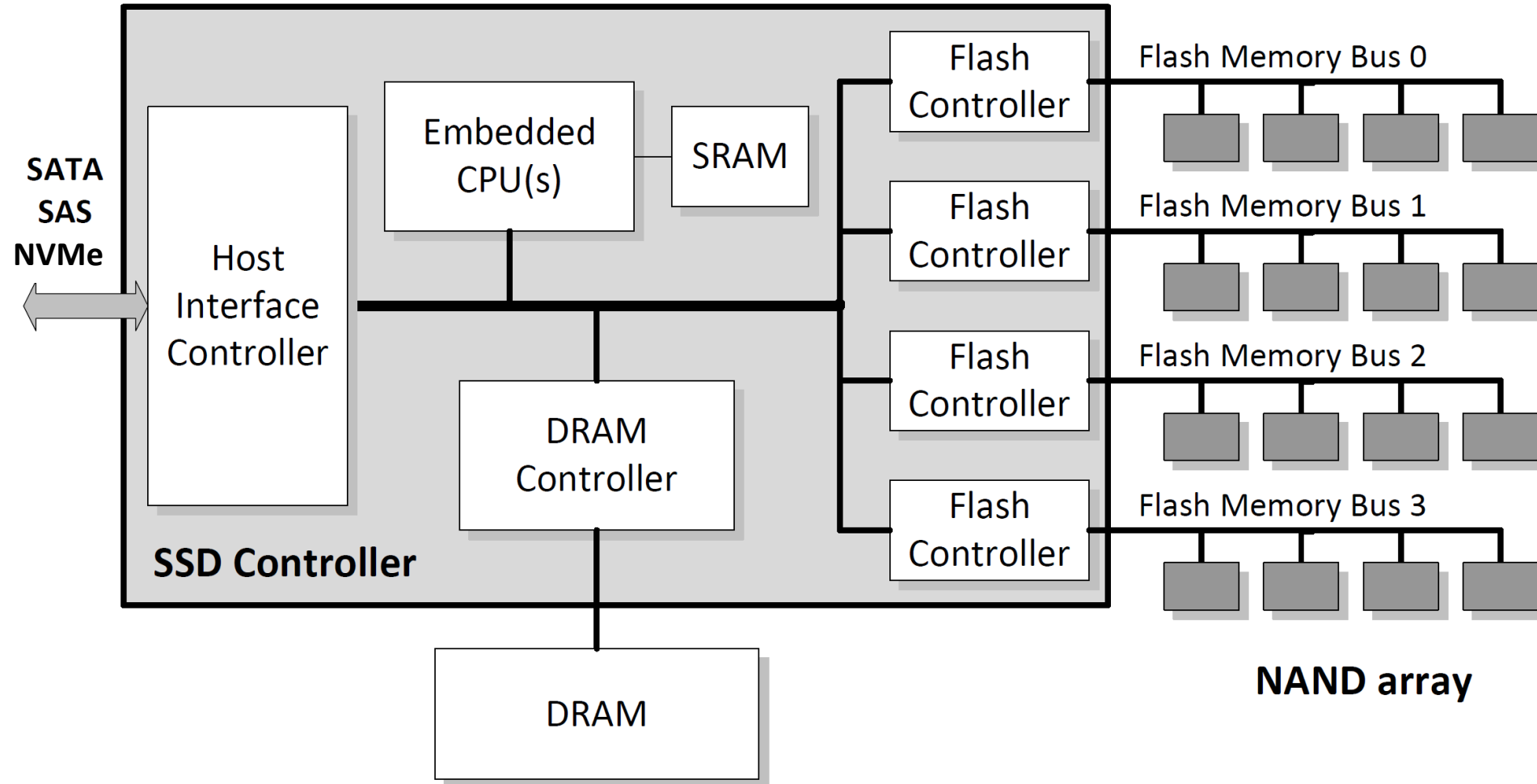

# Moving Closer to the Processor

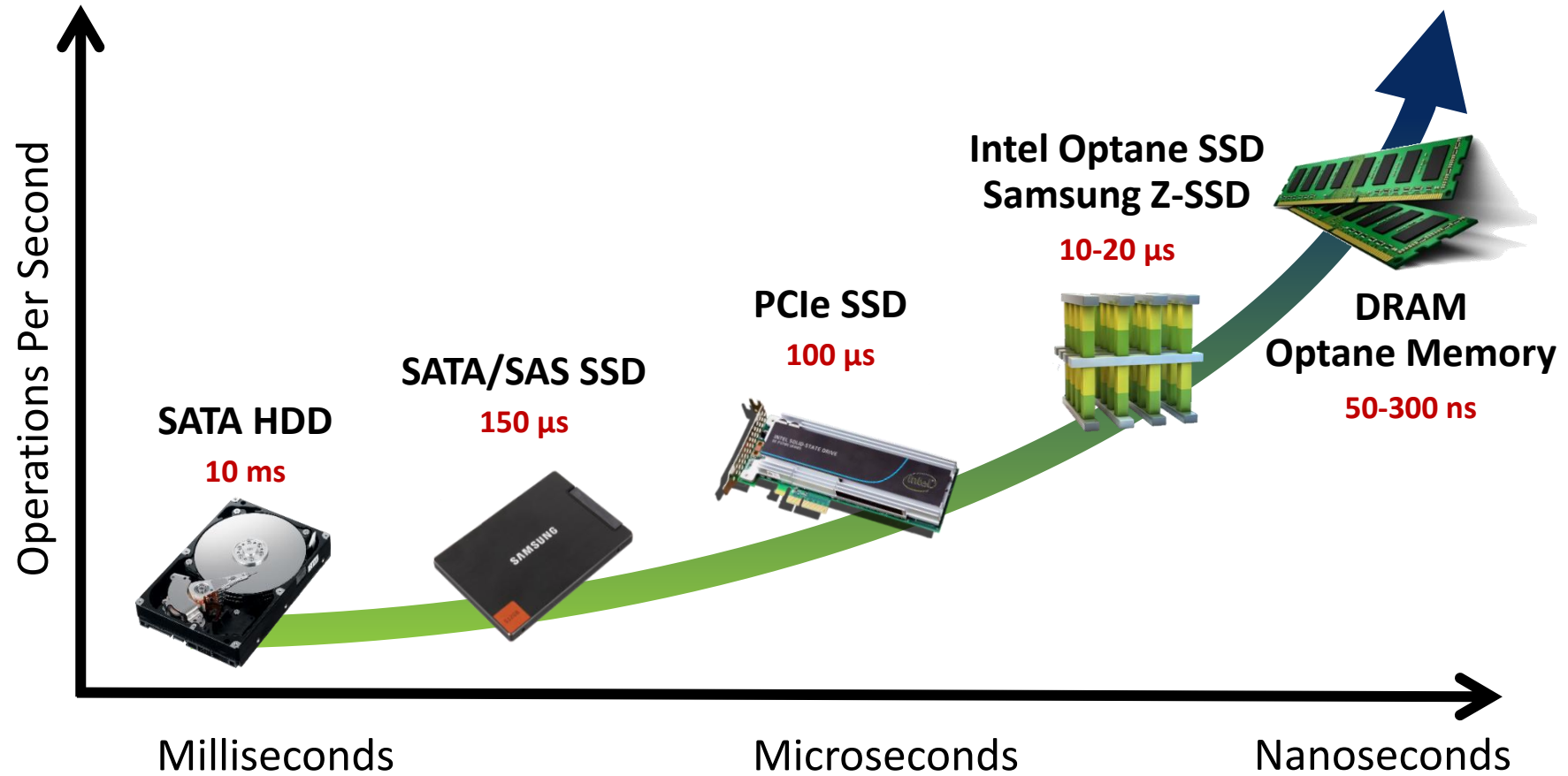

# NVMe (NVM Express)

- The industry standard interface for high-performance NVM storage
  - NVMe 1.0 in 2011 by NVM Express Workgroup
  - NVMe 2.0 in 2021
- PCIe-based
- Lower latency
  - Direct connection to CPU
  - No HBA (Host Bus Adapter) required: reduced power and cost
- Scalable bandwidth
  - 1 GB/s per lane (PCIe Gen3)
  - Up to 32 lanes

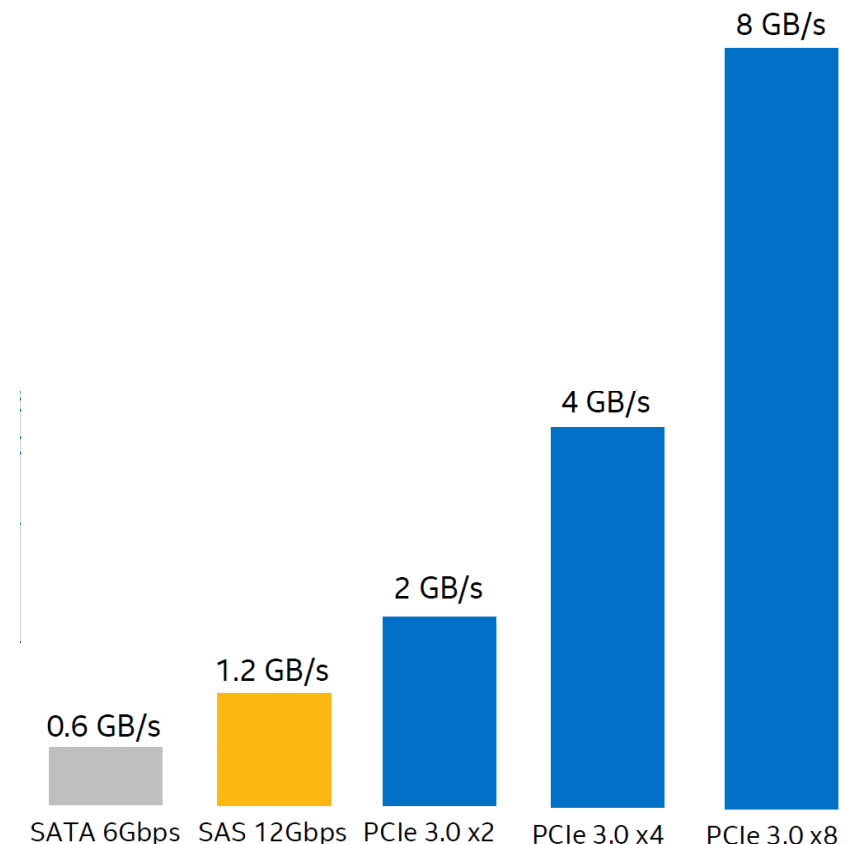

# NVMe Benefits

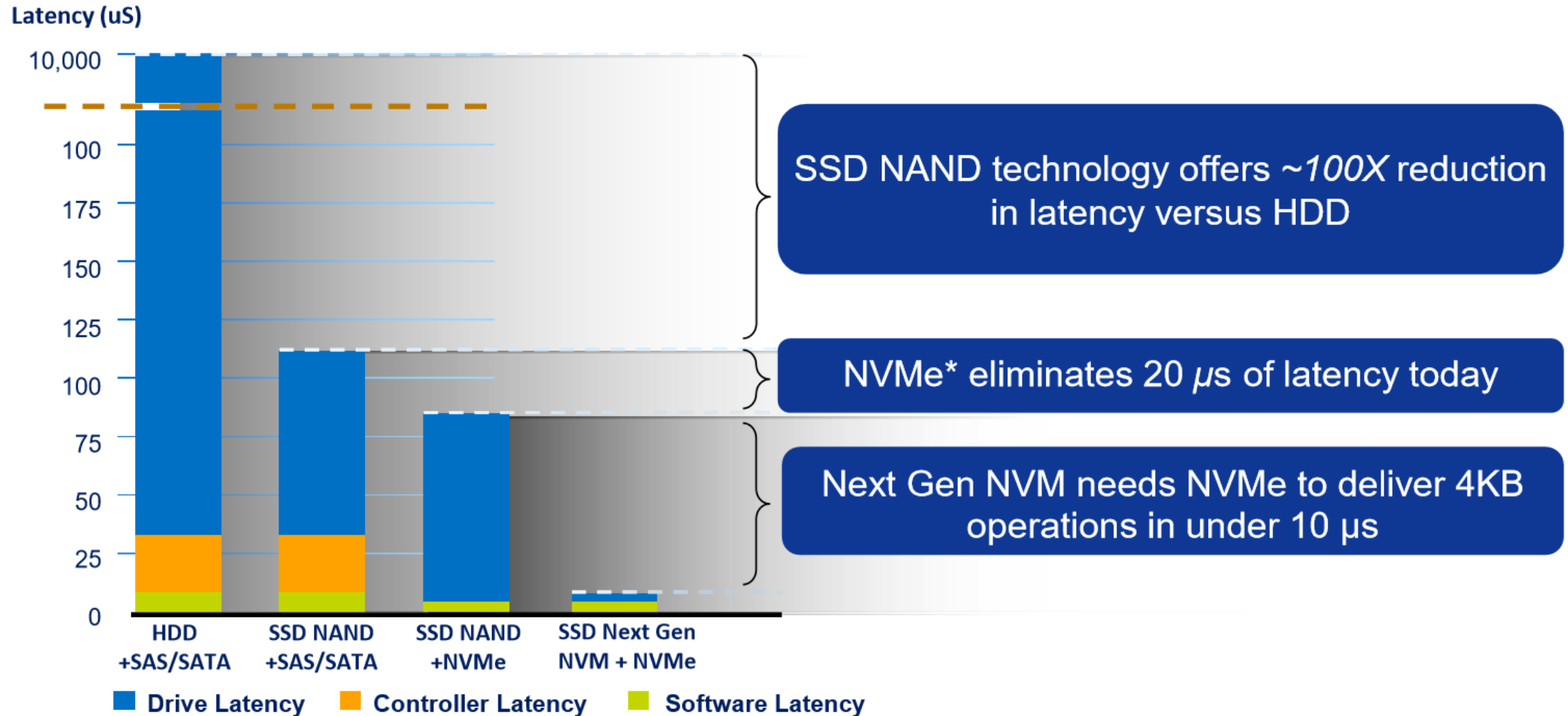

# NVMe Overview (<https://nvmexpress.org>)

- High-performance interface for SSDs
  - PCIe-based: 1 GB/s per lane (Gen. 3), up to 32 lanes
  - Optimized queueing interface: 64K commands per queue, up to 64K queues
  - Streamlined command set: only 13 required commands
  - One register write to issue a command ("doorbell") with MSI-X support

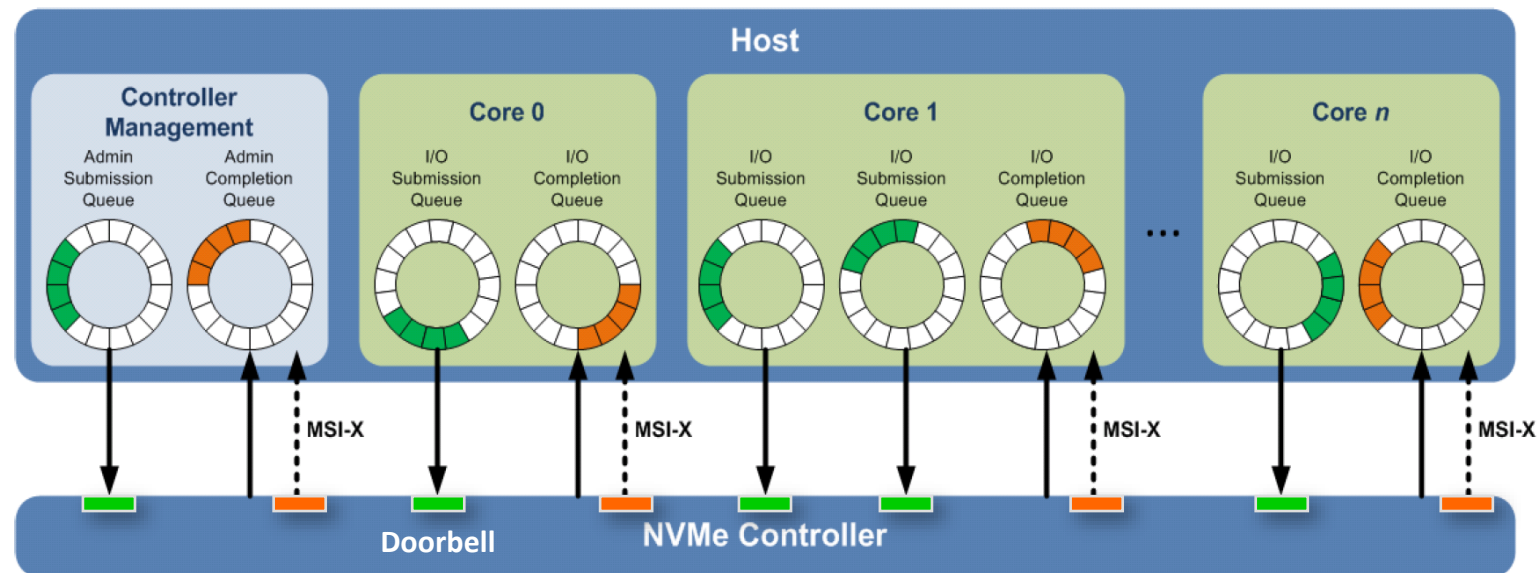

# NVMe Command Execution

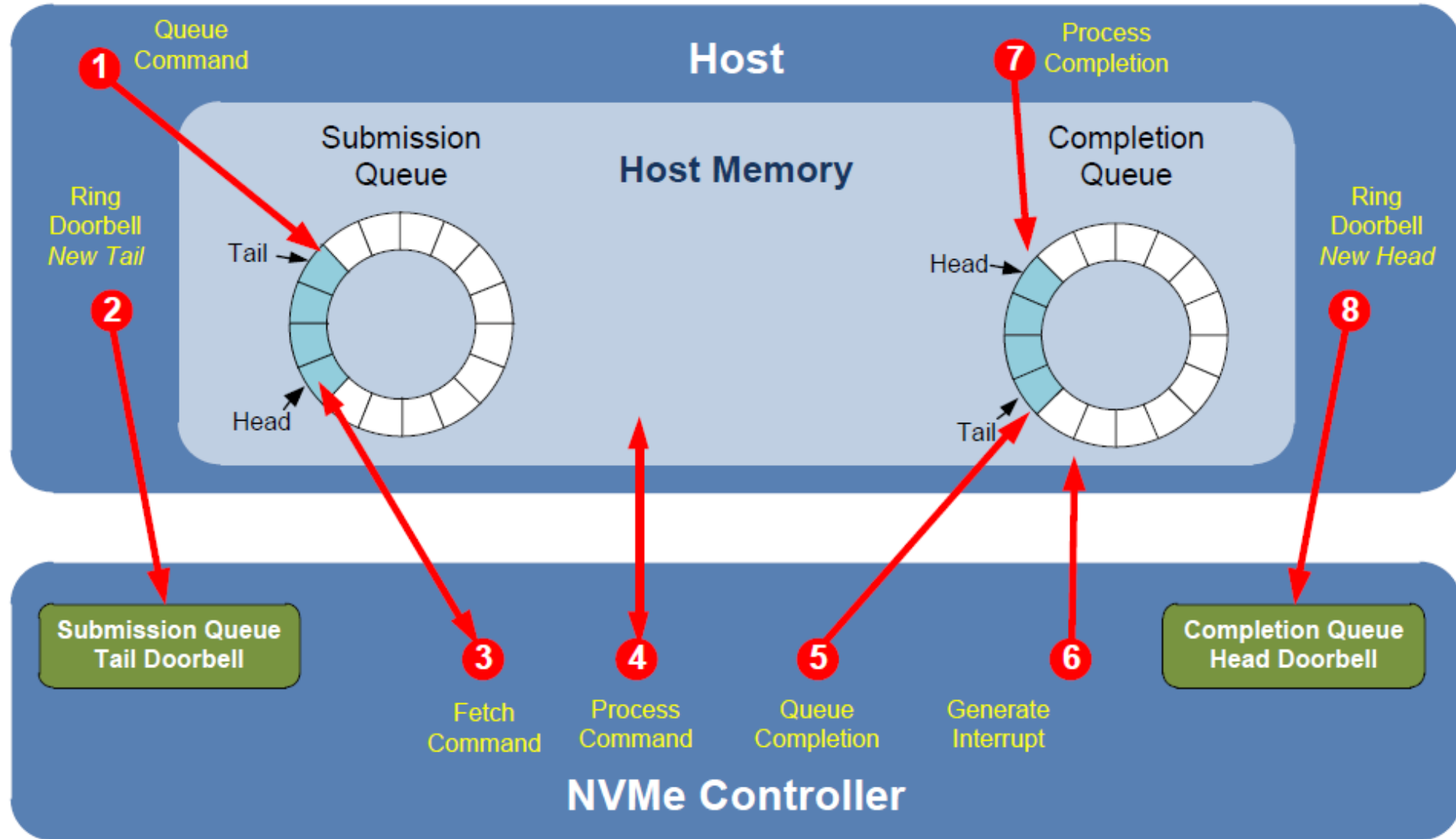

# For More on NVMe:



[고수의 세미나] 최진용 박사의 NVMe를 알려주마! - Part 1: PCIe 기초



[고수의 세미나] 최진용 박사의 NVMe를 알려주마! - Part 2: 왜 NVMe인가?



[고수의 세미나] 최진용 박사의 NVMe를 알려주마! - Part 3: NVMe 동작 원리

# NVMe SSD Form Factors (I)



Add-in-card (AIC)



U.2  
(SFF-8639:  
Up to x4)

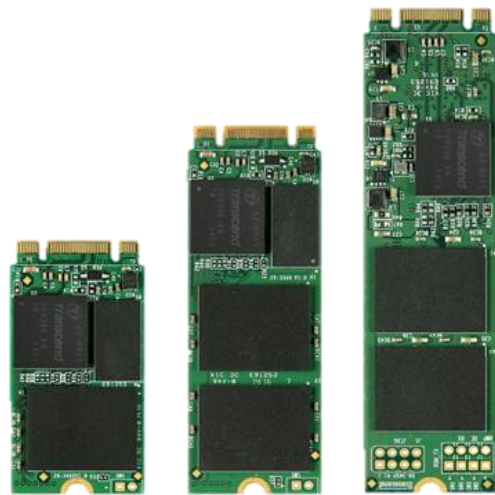

2242    2260    2280  
M.2 (PCIe: Up to x4)

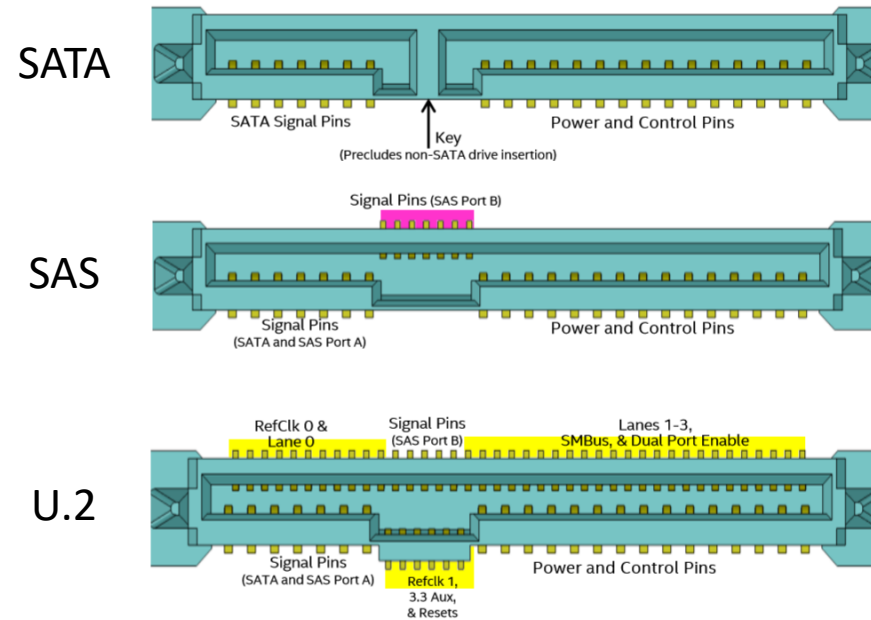

# NVMe SSD Form Factors (2)

- EDSFF (Enterprise and Data center SSD Form Factor)



**E1.L**

9.5 x 318.75mm  
18 x 318.75mm

**E1.S**

31.5 x 111.49mm  
33.75 x 118.75mm

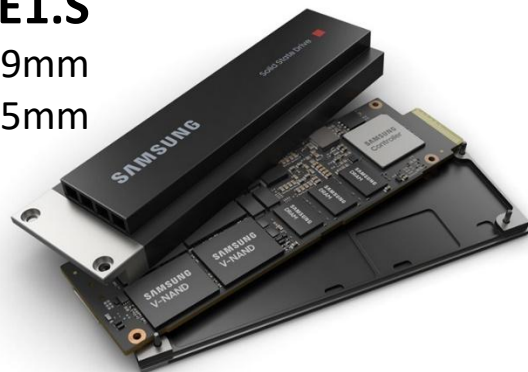

## Interoperable Device Sizes

Smaller devices fit within larger envelopes

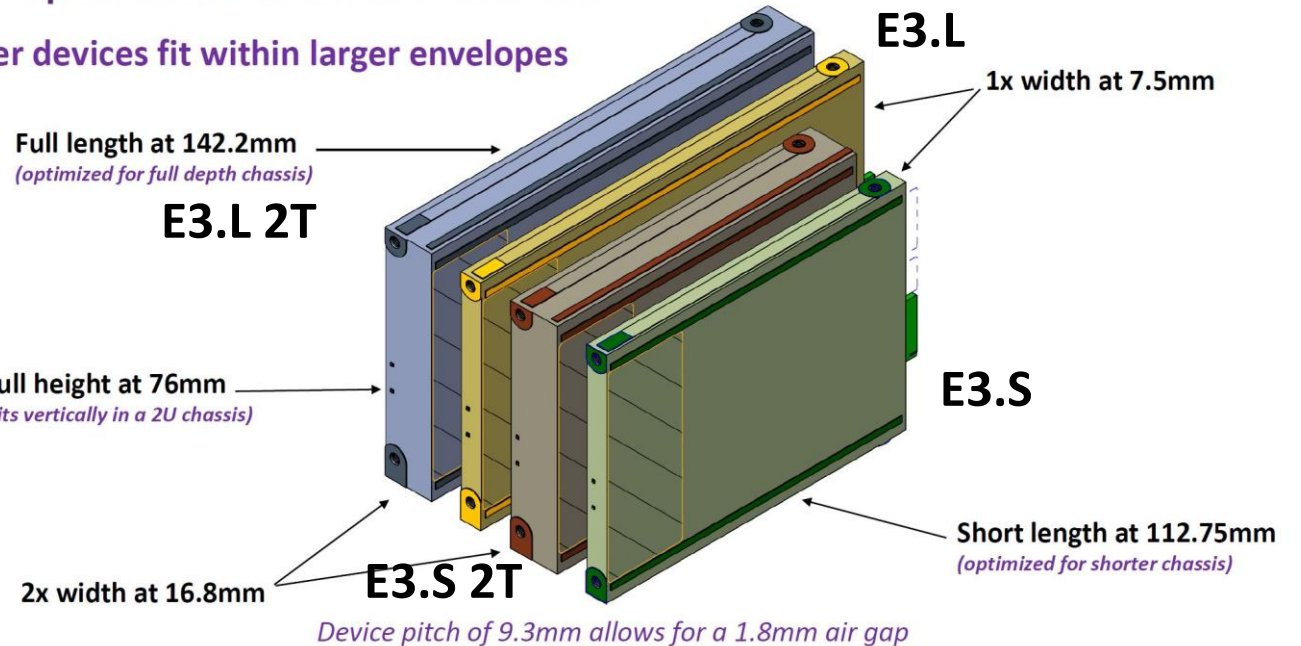

Source: <https://www.intel.com/content/www/us/en/products/docs/memory-storage/solid-state-drives/edsff-brief.html>  
<https://news.samsung.com/kr/삼성전자-데이터센터-전용-고성능-ssd-양산>  
<https://www.servethehome.com/e1-and-e3-edsff-to-take-over-from-m-2-and-2-5-in-ssds-kioxia/2/>

# eMMC

- **Embedded MultiMediaCard (JEDEC standard JESD84)**
  - Embedded storage solution with an MMC interface
  - Parallel, half-duplex interface with 1/4/8-bit data bus width
- **eMMC evolution**
  - eMMC 4.5: 1.6Gbps, 200MB/s, 2010 (Used in Galaxy S4)
  - eMMC 5.0: 3.2Gbps, 400MB/s, 2013 (Used in Galaxy S5)
  - eMMC 5.1: 3.2Gbps, 400MB/s, 2015
- **Synchronous operation**
  - One command at a time
  - Packed command (4.5+)
  - Command queuing (5.1, up to 32)

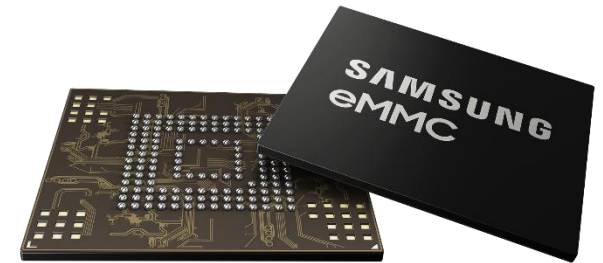
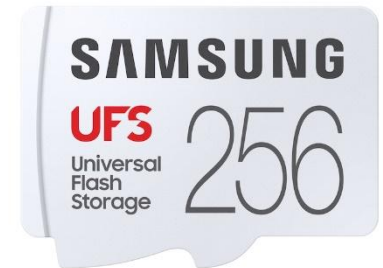
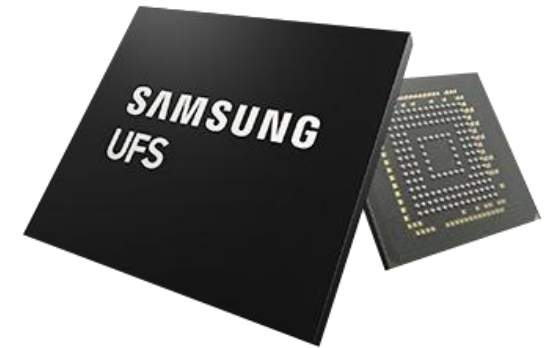

Image from <https://news.samsung.com/>

# UFS

- **Universal Flash Storage (JEDEC standard JESD220)**
  - Next generation flash storage for mobile devices
  - High-speed, full-duplex, serial interface
  - Based on SCSI command set
- **UFS evolution**
  - UFS 1.0: 150MB/s, single lane, 2011
  - UFS 2.0: 600MB/s, x2 lanes, 2013 (Used in Galaxy S6)
  - UFS 3.1: 1450MB/s, x2 lanes, 2020 (Used in Galaxy S21)
  - UFS 4.0: 2900MB/s, x2 lanes, 2022 (Used in Galaxy S23)
- **Asynchronous operation**
  - Higher random IOPS due to command queuing (up to 256)



# Summary

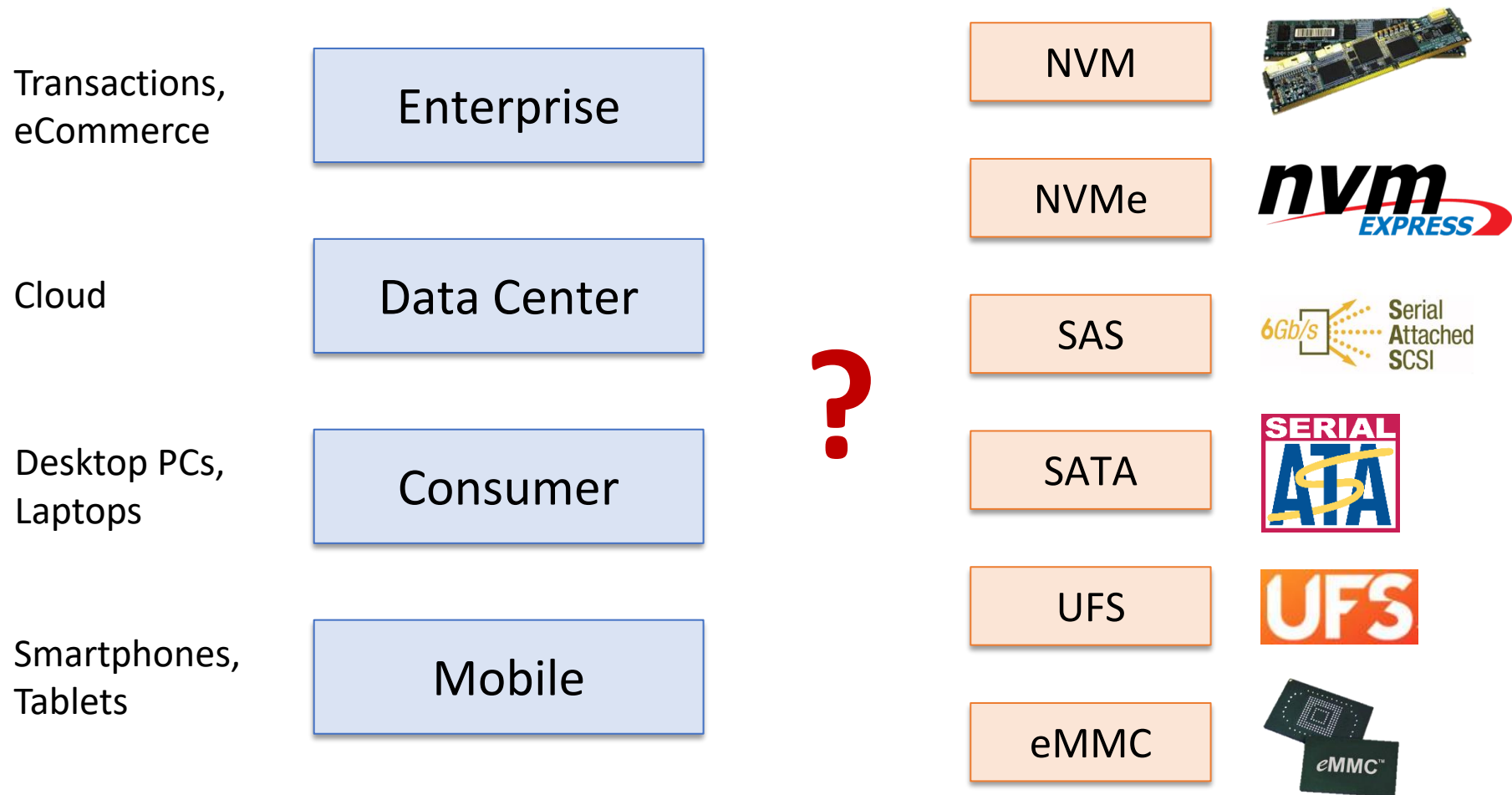

Storage

# Storage: A Logical View

- Abstraction given by block device drivers ("*block interface*")



- **Operations**

- Identify(): returns N
- Read (start sector #, # of sectors, buffer address)
- Write (start sector #, # of sectors, buffer address)

# DAS

## ■ Direct-Attached Storage

- Simple to deploy
- Lower initial cost
- Sharing data?
- Load balancing?
- Scalability?
- Fault tolerance?

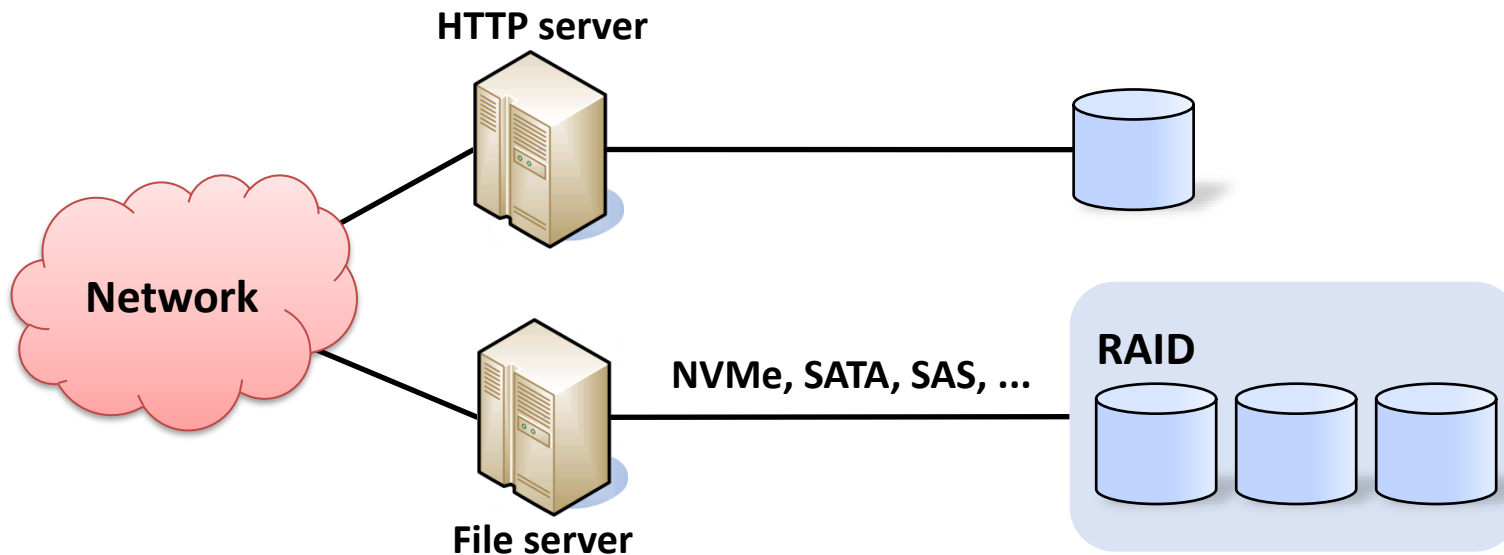

# SAN

## ■ Storage Area Network

- Block-level data sharing
- High performance
- High availability
- Sharing files?
- Cost?
- Management complexity?
- Interoperability?

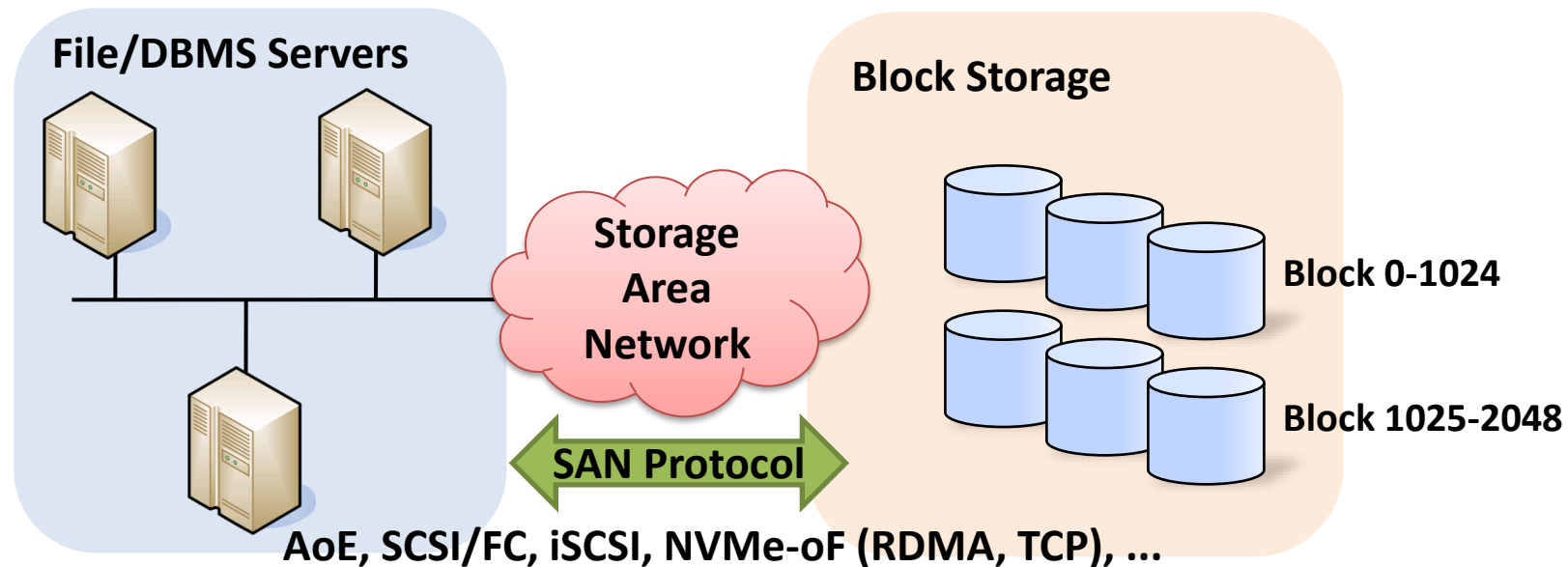

# NAS

## ■ Network-Attached Storage

- File-level data sharing
- Easy to install & deploy
- Heterogeneous systems support
- Static data partitioning
- Scalability?
- Automatic load balancing?
- Transparent migration?

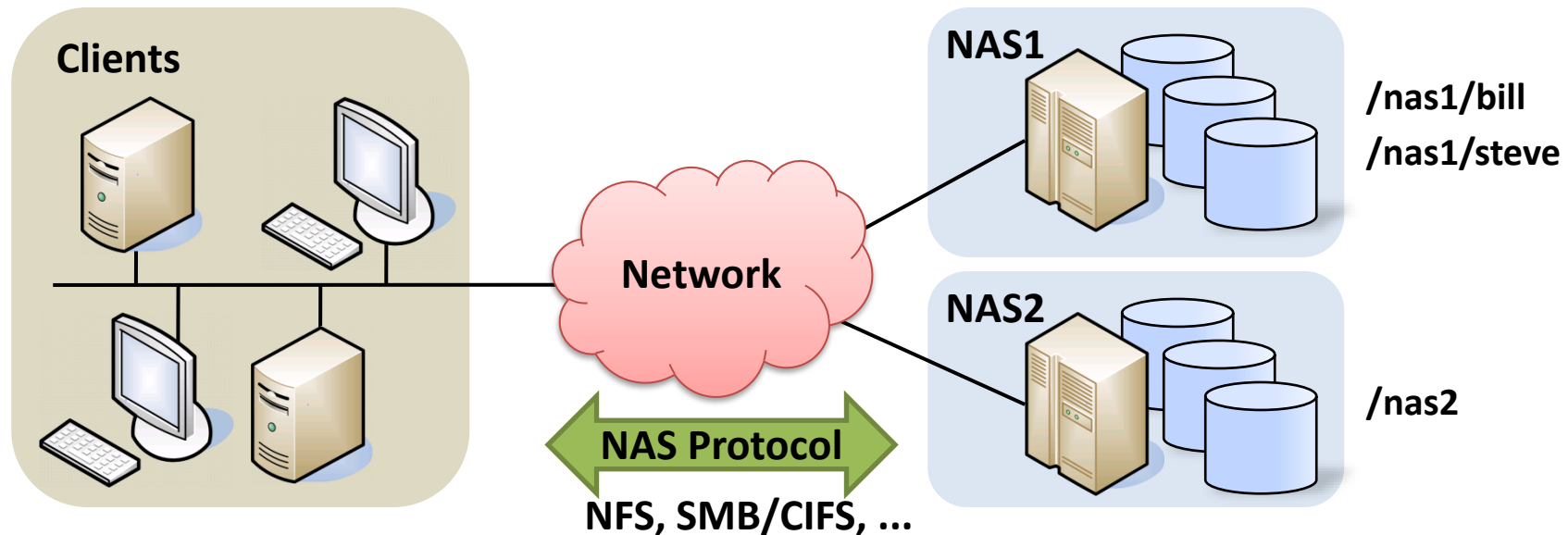

# NAS/SAN Convergence

## ■ NAS Head

- A NAS with no on-board storage (connected to a SAN)
- File system operations → Block device operations
- Cache file contents

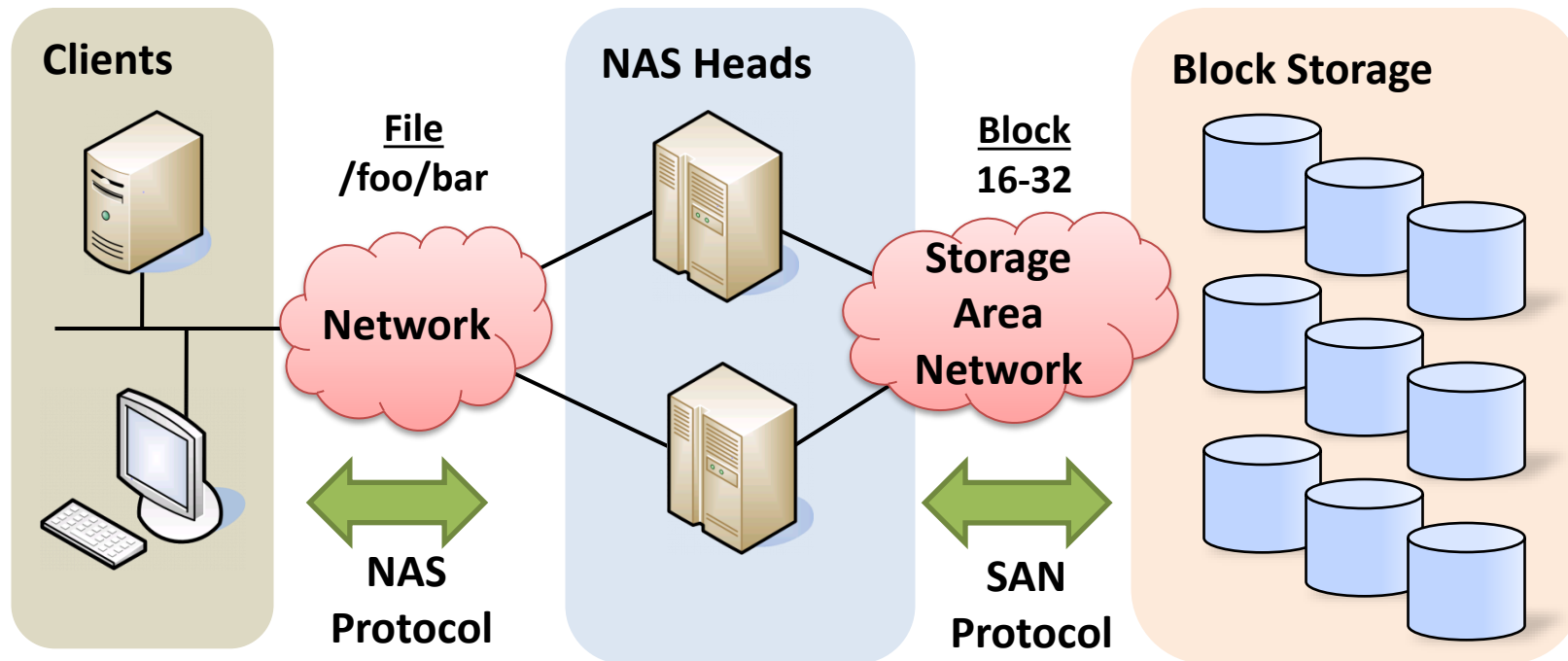

# SNIA Shared Storage Model (SSM)

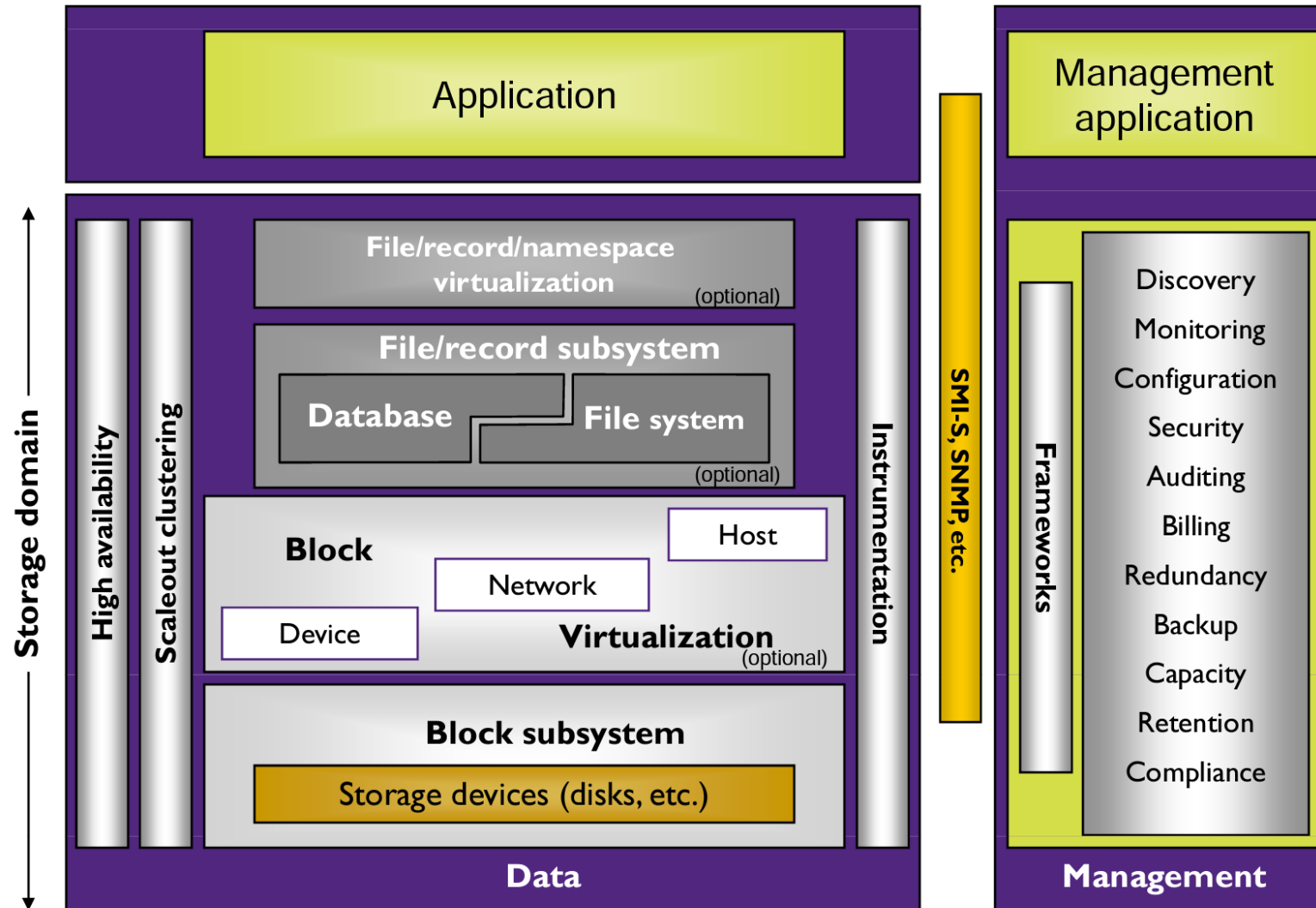

Source: [https://www.snia.org/education/storage\\_networking\\_primer/shared\\_storage\\_model](https://www.snia.org/education/storage_networking_primer/shared_storage_model)

# File/Record Layer

- "Access methods"
  - File system, DBMSes
- Primary responsibility
  - Fine-grain naming & indexing
  - Space allocation and clustering
  - Protection, etc.
- Secondary responsibility
  - Caching for performance
  - Coherency in distributed systems

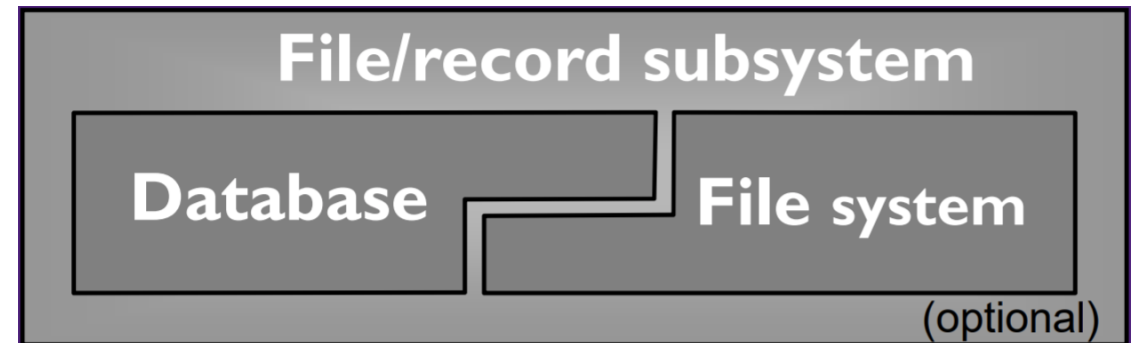

# File/Record Layer: Where?

- Solely in the host
  - Traditional host-based file systems and DBMSes
- In both client and server
  - Split their functions between the client (host) and the server system (e.g., network file systems: NFS, CIFS, etc.)
  - **File (database) server**: a host with locally attached block storage device
  - **NAS head**: a dedicated-function computer acting as a file server and relying on external block storage devices
  - **Storage device**: disk array or "smart disk"

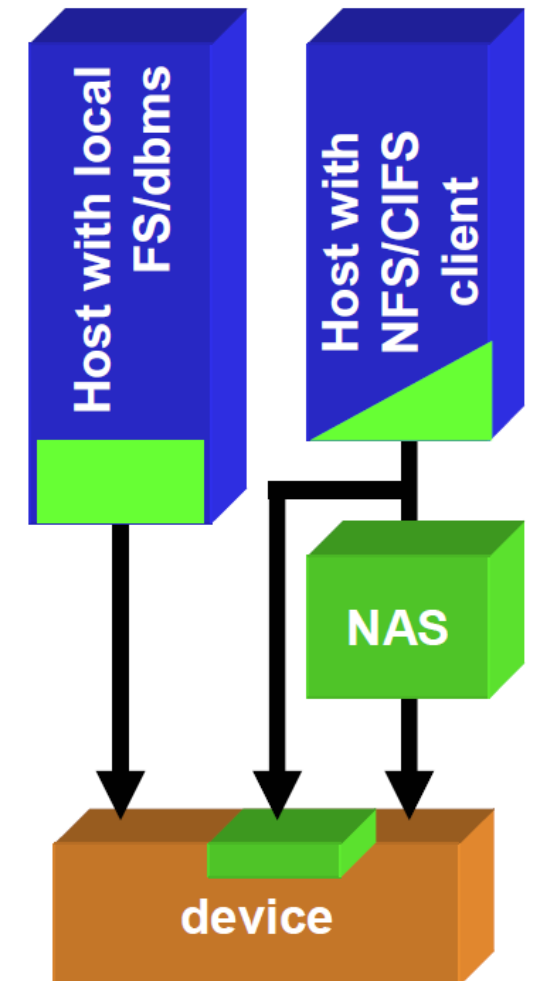

# Block Layer

- **Primary responsibility**
  - Providing low-level storage to higher layers with an access interface that supports one or more linear vectors of fixed-size blocks (e.g., SCSI Logical Units (LUs))
- **Secondary responsibility**
  - Caching
  - Tiering
- **"Native" storage devices**
  - Disk drives, SSDs, tape drives, ...
- **Block aggregation**
  - Aggregation or "virtualization"

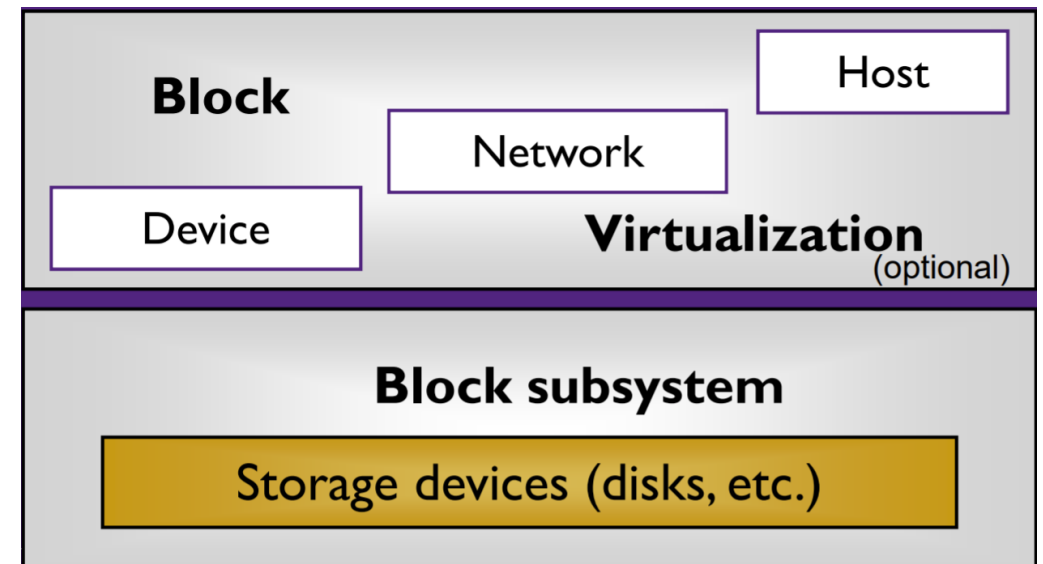

# Block Aggregation

- **Space management**
  - Constructing a large block vector by assembling many smaller ones
  - Partitioning one larger block vector into many smaller logical ones
- **Striping**
  - For performance (load balancing, throughput, etc.)
- **Redundancy**
  - Full: local & remote mirroring, RAID-1/10, ...
  - Partial: RAID-3/4/5, ...
  - Snapshots

# Block Aggregation: Where?

## ■ Host-side

- Logical Volume Managers (LVMs)
  - Mapping between logical volume and physical volume (linear, striped, ...)
  - Resizing a logical volume, snapshot support, ...
- Software RAIDs, device drivers, HBAs, ...

## ■ Storage Network (SN)-based

- Specialized SN appliances

## ■ Device-based

- Disk arrays or Flash arrays
- RAID controllers
- Disk controllers

**Storage network(SN):**  
any dedicated network  
installed for storage traffic  
(Fibre channel, Ethernet, etc.)

