

Jin-Soo Kim  
([jinsoo.kim@snu.ac.kr](mailto:jinsoo.kim@snu.ac.kr))

Systems Software &  
Architecture Lab.  
Seoul National University

Spring 2026

# Memory Mapping



# Virtual Memory Area

- Virtual address space is a resource
  - Every memory area should be allocated in the virtual address space
  - If you run out of the virtual address space, you can not access any more memory (even if you have space in the physical memory)
- Some of memory areas are backed by files and some aren't

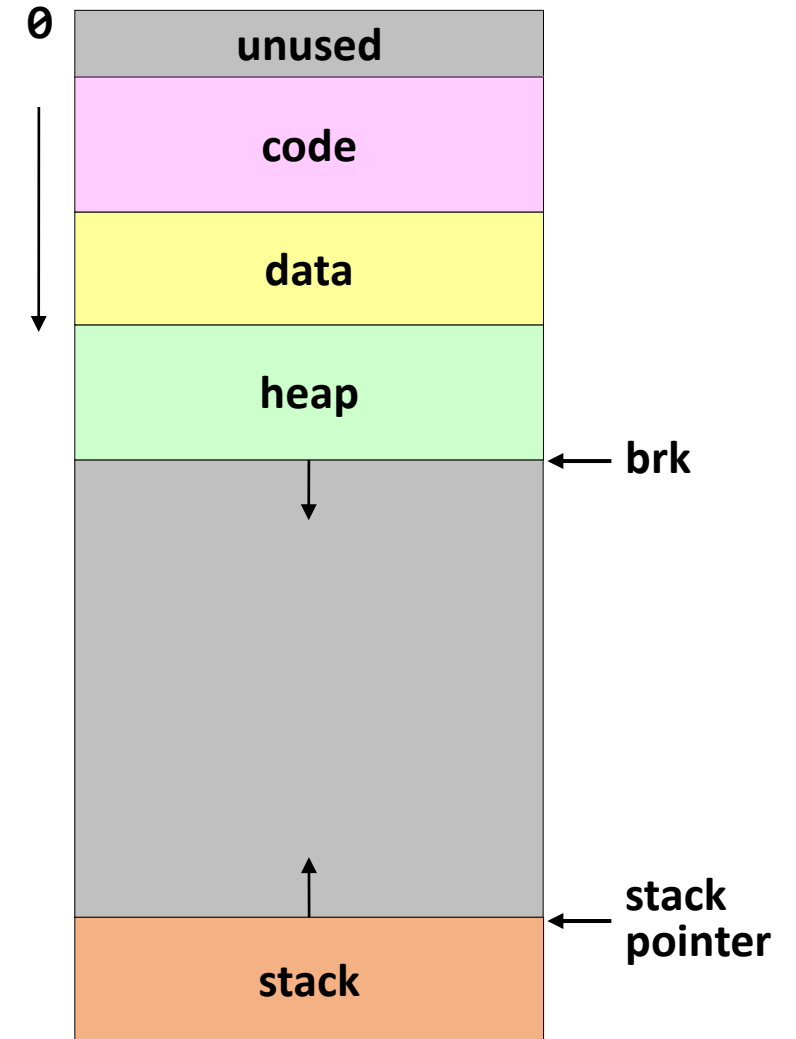

# Memory Mapping

- A dynamically allocated virtual memory area that has a backing store
  - File
  - Device memory
  - Shared memory
  - None

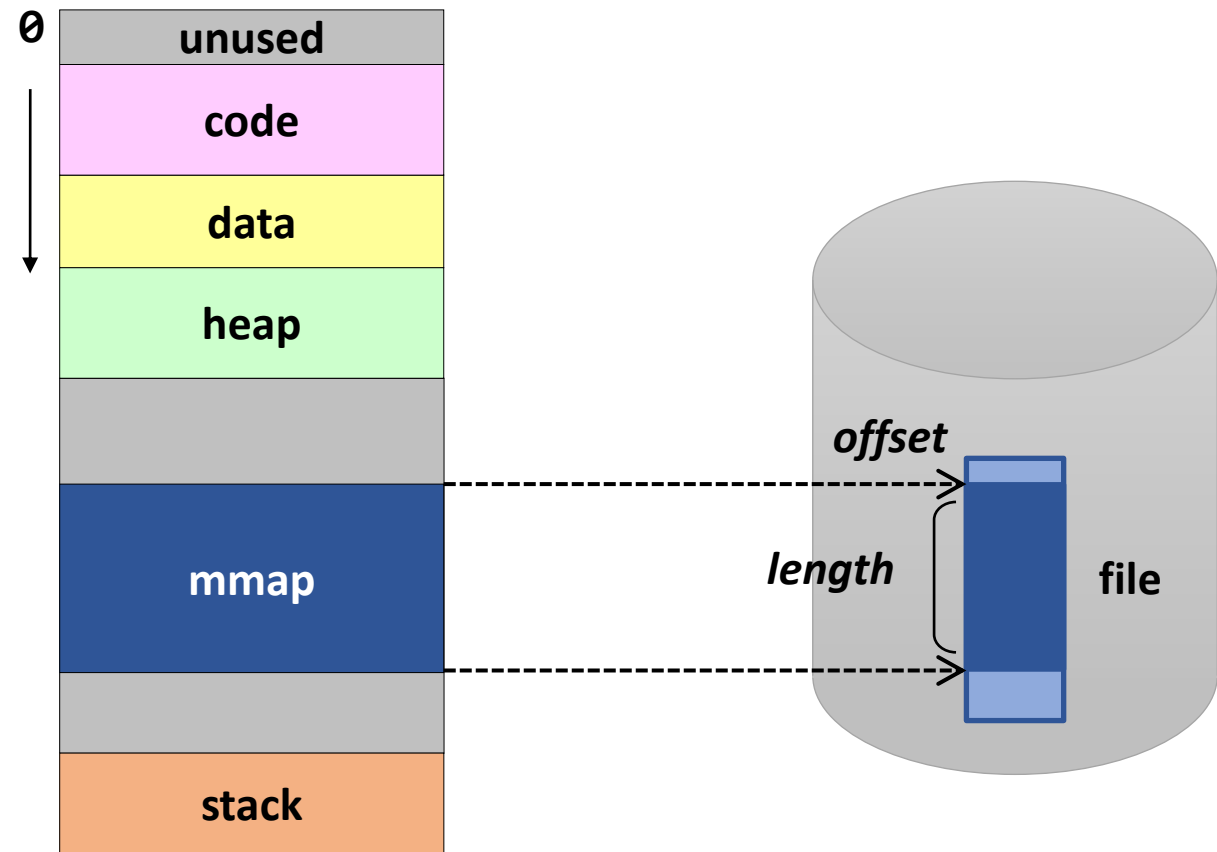

# File vs. Anonymous Mapping

- **File mapping (memory-mapped file)**
  - Backing store: regular file
  - Maps a memory region to a file region
  - The content of the file can be read from or written to using load/store instructions
  
- **Anonymous mapping**
  - Virtual address space not backed by a file
  - Maps a memory region to a memory area filled with 0
  - Zero-page mapping

# Shared vs. Private Mapping

- Several processes can map the same backing store in their own virtual address space
- Shared mapping
  - Modifications to shared pages are visible to all involved processes
- Private mapping
  - Modifications are not visible to other processes
  - Copy-on-write

	<b>File mapping</b>	<b>Anonymous mapping</b>
<b>Private</b>	Private file mapping	Private anonymous mapping
<b>Shared</b>	Shared file mapping	Shared anonymous mapping

# mmap()

```
void *mmap(void *addr, size_t length, int prot, int flags,  
           int fd, off_t offset);
```

- **Creates a new mapping in the virtual address space of the calling process**
  - **addr**: the starting address for the new mapping (should be aligned to page boundary)
    - If NULL, the kernel chooses the address
    - Otherwise, the kernel takes it as a hint about where to place the mapping
  - **length**: the length of the mapping
  - **prot**: protection info. (PROT\_EXEC, PROT\_READ, PROT\_WRITE, PROT\_NONE)
  - **flags**: mapping flags (MAP\_PRIVATE, MAP\_SHARED, MAP\_ANONYMOUS, ...)
  - **fd, offset**: file descriptor & file offset (used for file mapping)

# Memory-Mapped File: Example

- Allows processes to perform file I/O using memory references
  - Instead of `open()`, `read()`, `write()`, `close()`, etc.
  - Map a file to a virtual memory region

```
#include <unistd.h>
#include <fcntl.h>
#include <stdio.h>
#include <sys/mman.h>

int main(int argc, char *argv[]) {
    int fd = open("/bin/ls", O_RDONLY);
    char *p = (char *) mmap(0, 4096, PROT_READ, MAP_SHARED, fd, 0);
    printf("%#04x %#04x %#04x %#04x\n", *p, *(p+1), *(p+2), *(p+3));
    close(fd);
}
```

# Memory-Mapped File

## ■ Implementation

- Initially, all pages in mapped region are marked as invalid
- OS reads a page from file whenever invalid page is accessed
- PTEs map virtual addresses to page frames holding file data
- $\langle \text{Virtual address base} + n \rangle$  refers to  $\text{offset} + n$  in file

## ■ Writes to the memory-mapped area

- If `MAP_SHARED`,  
OS writes to a page and it is written to the file when evicted from physical memory
- If `MAP_PRIVATE`,  
OS creates a private copy and then write data to the page. (a.k.a. Copy-On-Write)  
File is not modified.

# File I/O Comparisons

```
char buf[1024];  
int fd = open("a",...);  
read(fd, buf, 1024);
```

```
char buf[4096];  
int fd = open("a",...,  
             O_DIRECT);  
read(fd, buf, 4096);
```

```
char buf[1024];  
FILE *fp = fopen("a","r");  
fgets(buf, 1024, fp);
```

```
int fd = open("a",...);  
char *p = mmap(0,.., fd, 0);
```

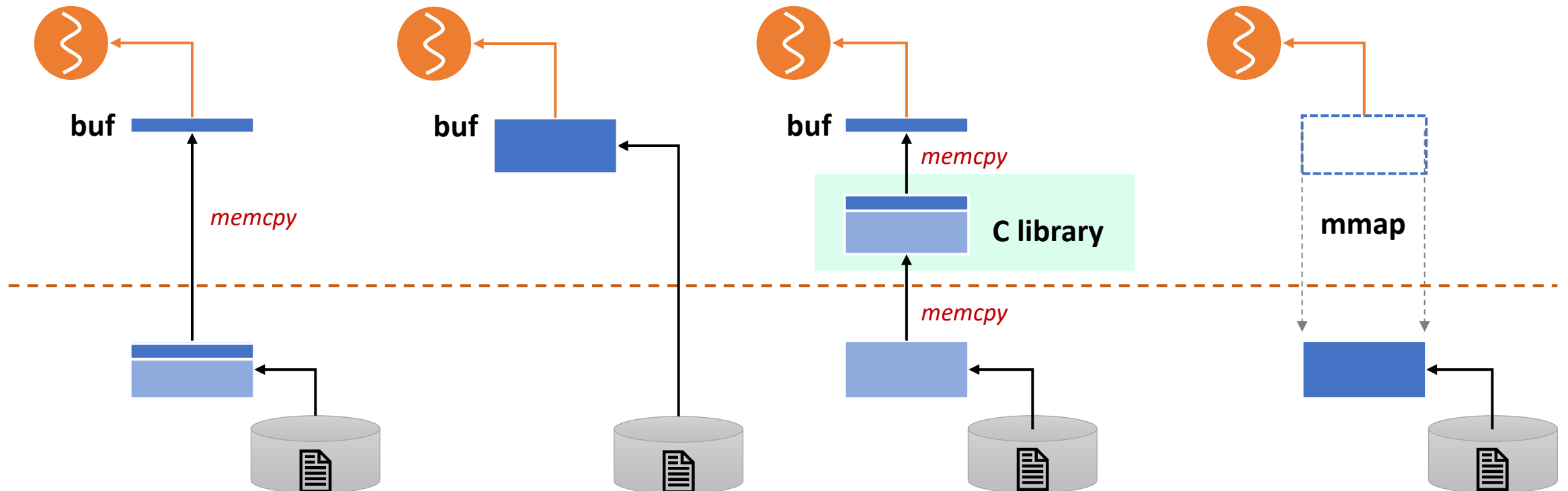

# Summary: Memory-Mapped File

## ■ Pros

- Uniform access for files and memory (just use pointers)
- Less memory copying
- Several processes can map the same file allowing the pages in memory to be shared

## ■ Cons

- Process has less control over data movement
- Does not generalize to streamed I/O (pipes, sockets, etc.)

# Shared Memory: Example

- Allows (unrelated) processes to share data using direct memory reference

```
#include <sys/mman.h>
#include <stdio.h>
#include <fcntl.h>
#include <unistd.h>

int main(int argc, char *argv[]) {
    int fd = shm_open("/shm1", O_CREAT | O_EXCL | O_RDWR, 0600);
    ftruncate(fd, 4096); // set shmem size
    int *p = (int *) mmap(0, 4096, PROT_READ | PROT_WRITE, MAP_SHARED, fd, 0);
    for (int i = 0; i < 1024; i++) p[i] = i;
    close(fd);
}
```

# Shared Memory

## ■ Implementation

- Have PTEs in both tables map to the same physical frame
- Each PTE can have different protection values
- Must update both PTEs when a page becomes invalid

## ■ Mapping shared memory in the virtual address space

- At the different address: flexible (no address space conflicts), but pointers inside the shared memory are invalid
- At the same address: less flexible, but shared pointers are valid

# Copy-on-Write

- Defers memory copies as long as possible, hoping to avoid them altogether
- **Implementation**
  - Instead of copying pages, create shared mappings to the same page frames in physical memory
  - Shared pages are protected as read-only
  - When data is written to these pages, OS allocates new space in physical memory and directs the write to it
- **Usage**
  - `fork()`
  - Allocating data and heap pages, etc.

# Copy-on-Write during fork()

- COW ensures that both processes do not see each other's changes
  - Instead of copying all pages, create shared mappings of parent pages in the child address space
  - Shared pages are protected as read-only
  - Reads happen as usual
  - Writes generate a protection fault and OS copies the page, changes page mapping, and restarts write instruction
- Efficient when the child process calls `exec()` immediately after `fork()`

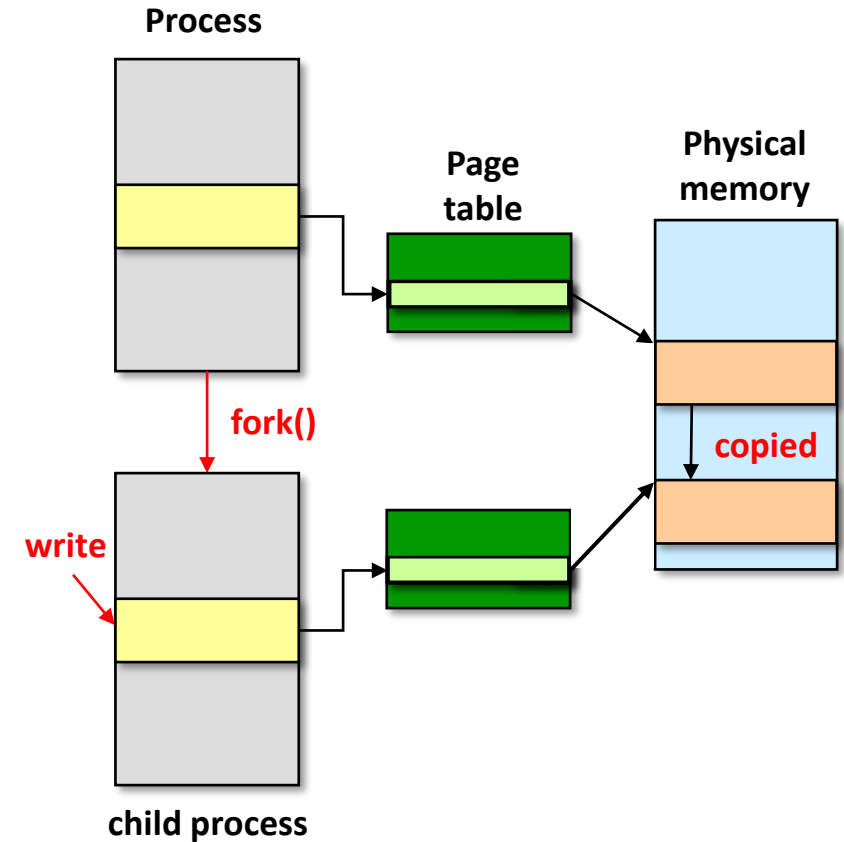

# Summary

