

Jin-Soo Kim
(jinsoo.kim@snu.ac.kr)

Systems Software &
Architecture Lab.
Seoul National University

Spring 2026

Page Tables



The Problem

- Space overhead of page tables

- A 32-bit address space with 4KB pages (4 bytes/PTE):
 $2^{20} * 4 = 4\text{MB}$ (per process)
- A 64-bit address space with 8KB pages (8 bytes/PTE):
 $2^{51} * 8 = 2^{54} = 16\text{PB}$ (per process)

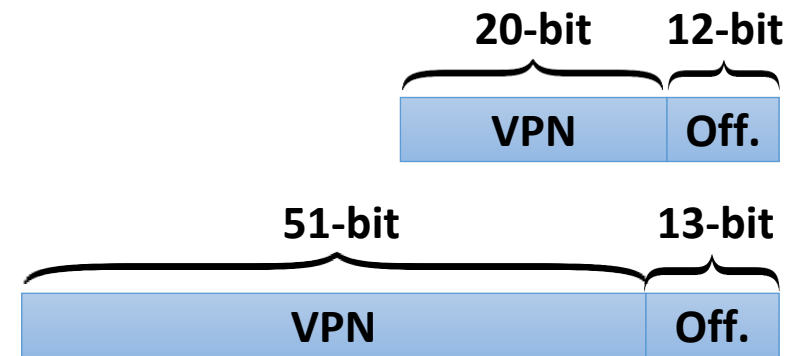

- How can we reduce this overhead?

- Observation: many invalid PTEs
- Only need to map the portion of the address space actually being used which is a tiny fraction of the entire address space

(Typical) Linear Page Table

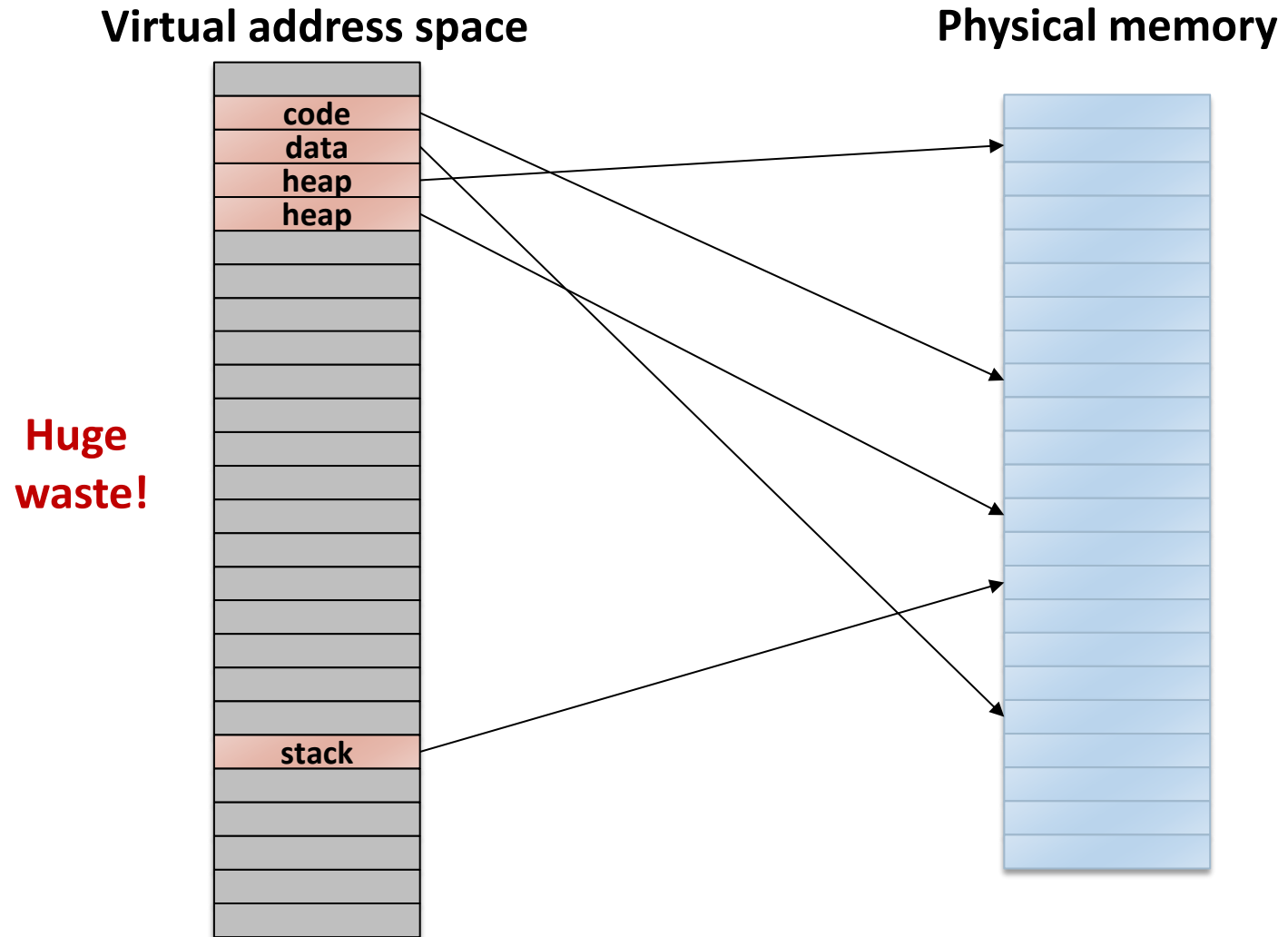

Paging with Segmentation

- A segment represents a region of valid address space
 - Segmentation:
 - Divide virtual address space into segments
 - Each segment can have variable length
 - Paging:
 - Divide each segment into fixed-sized pages
 - Each segment has a page table
 - Each segment tracks base (physical address) and limit of the page table for that segment
- Virtual address divided into three portions

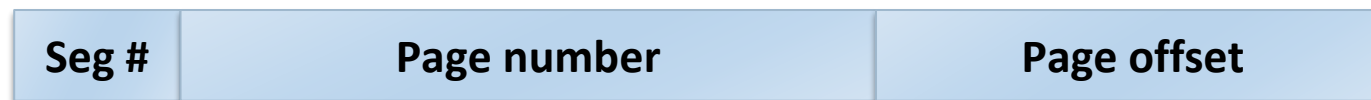

Paging with Segmentation: Example

- Multics address translation

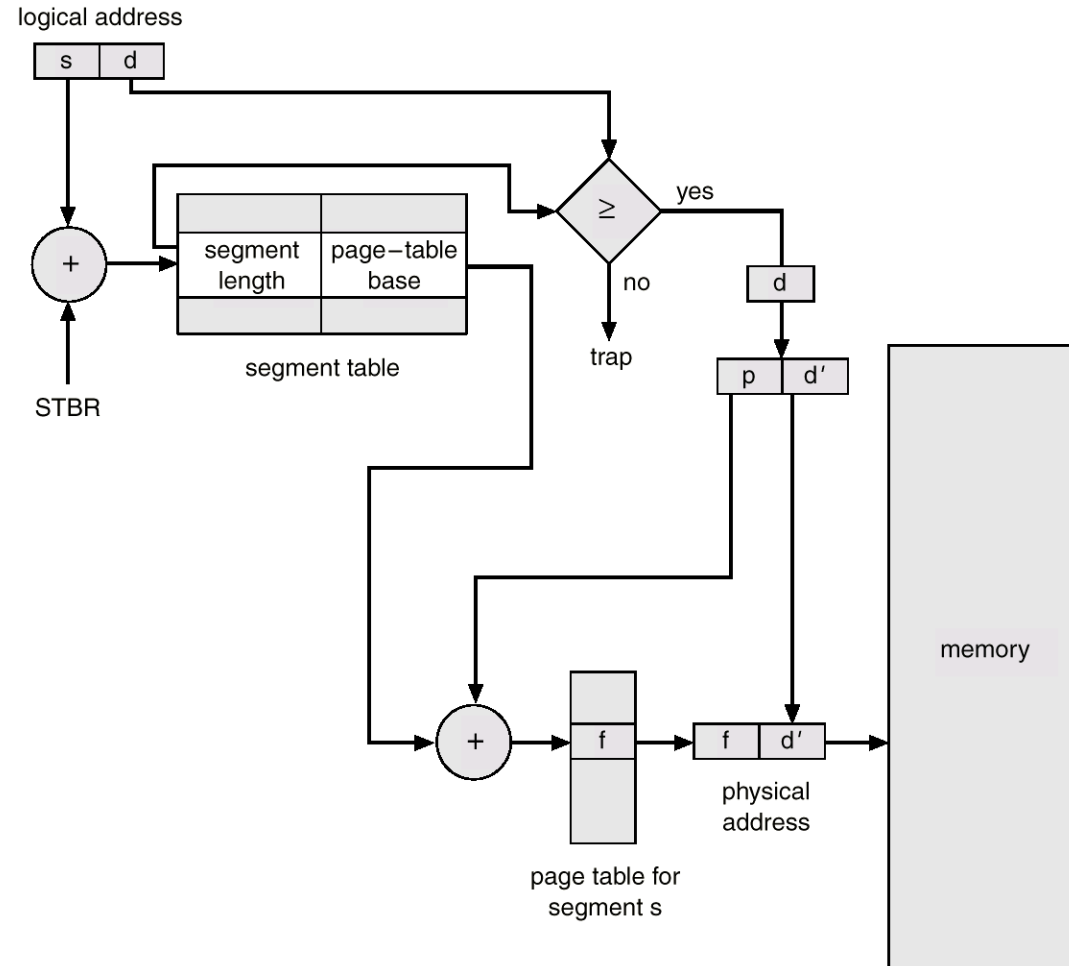

Summary: Paging with Segmentation

■ Pros

- Can decrease the size of page tables
- Segments can grow without any reshuffling
- Can run process when some pages are swapped to disk
- Increases flexibility of sharing: share either single page or entire segment

■ Cons

- Page tables potentially can be large
 - e.g., large but sparsely used heaps will have a lot of waste
- External fragmentation due to page tables
 - Each page table should be allocated contiguously

Linear vs. Multi-level Page Table

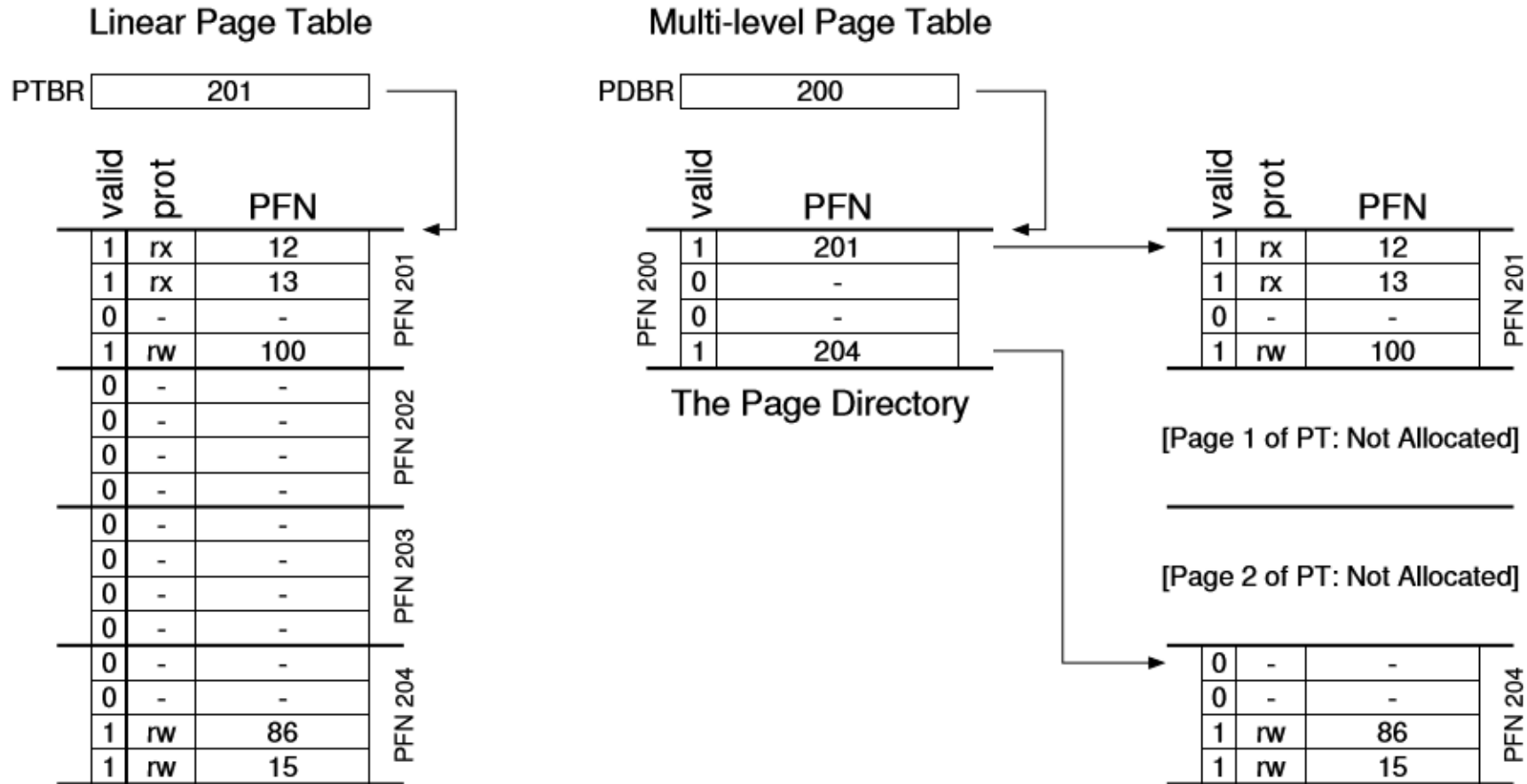

Multi-level Page Table

- Allow each page table to be allocated non-contiguously
- Virtual addresses have 3 parts



- Outer page table: outer page number \rightarrow secondary page table
- Secondary page table: secondary page # \rightarrow page frame #

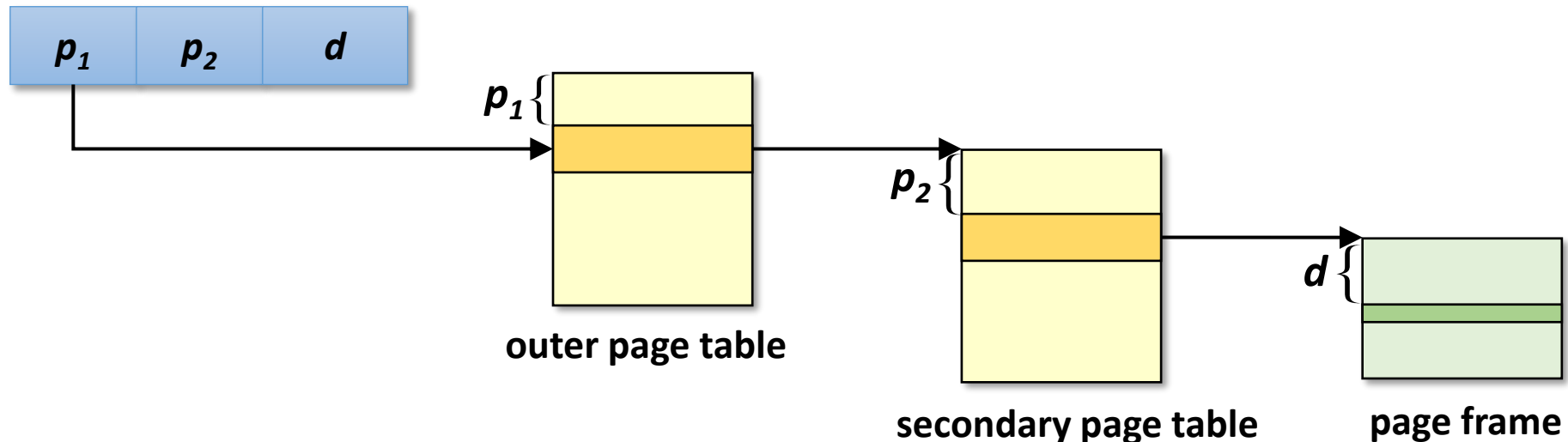

Multi-level Page Table: IA-32

- 32-bit paging
 - 32-bit address space, 4KB pages, 4 bytes/PTE
 - Want every page table to fit into a page

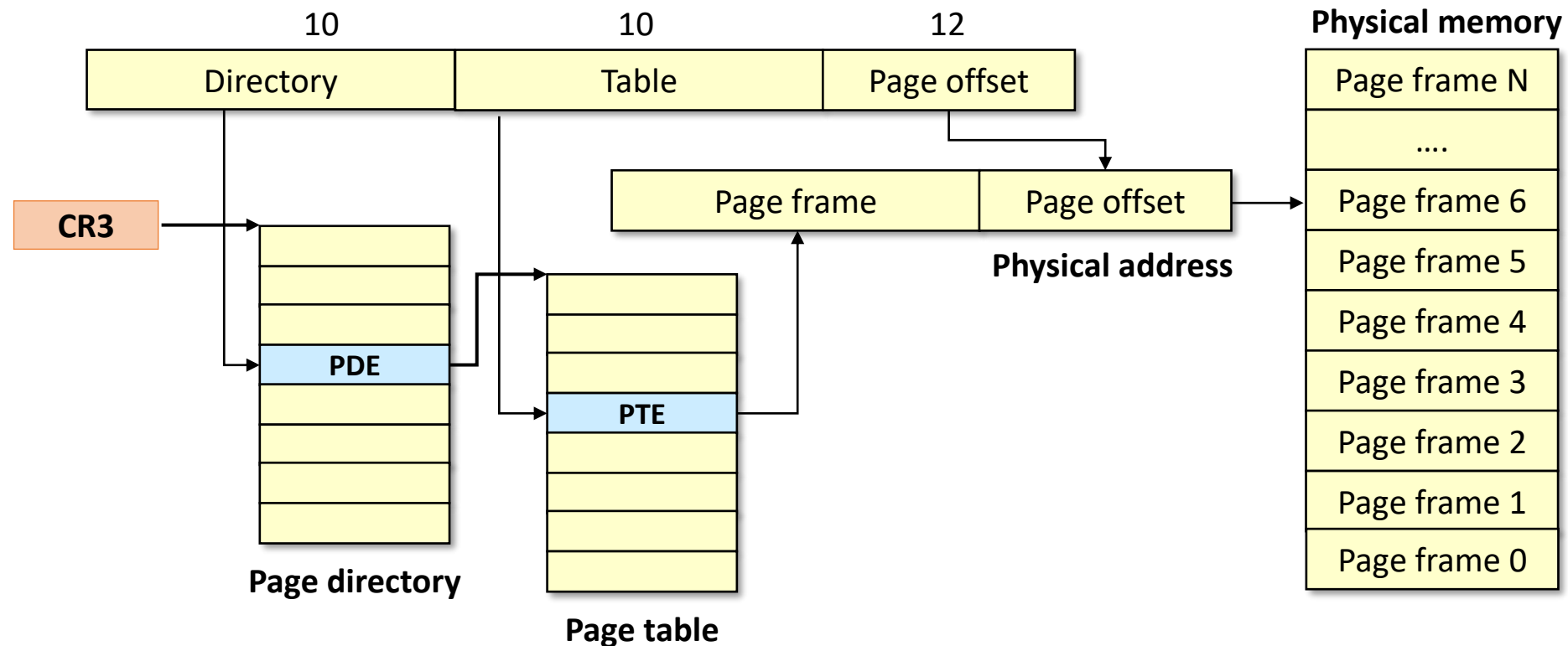

Multi-level Page Table: Intel 64

- Address translation in Intel 64 architecture
 - 48-bit “linear” address → 52-bit physical address (4KB page)

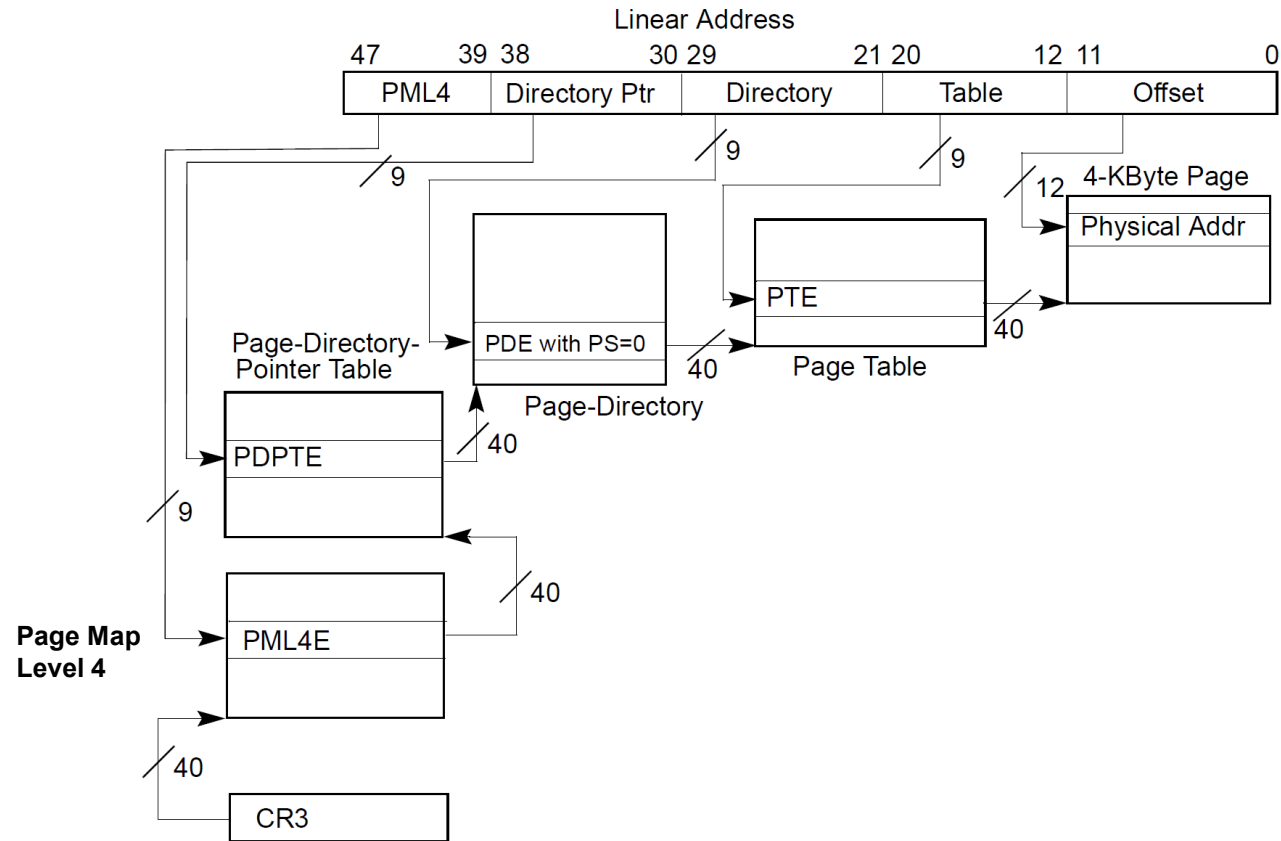

Intel VM Architecture (IA-32)

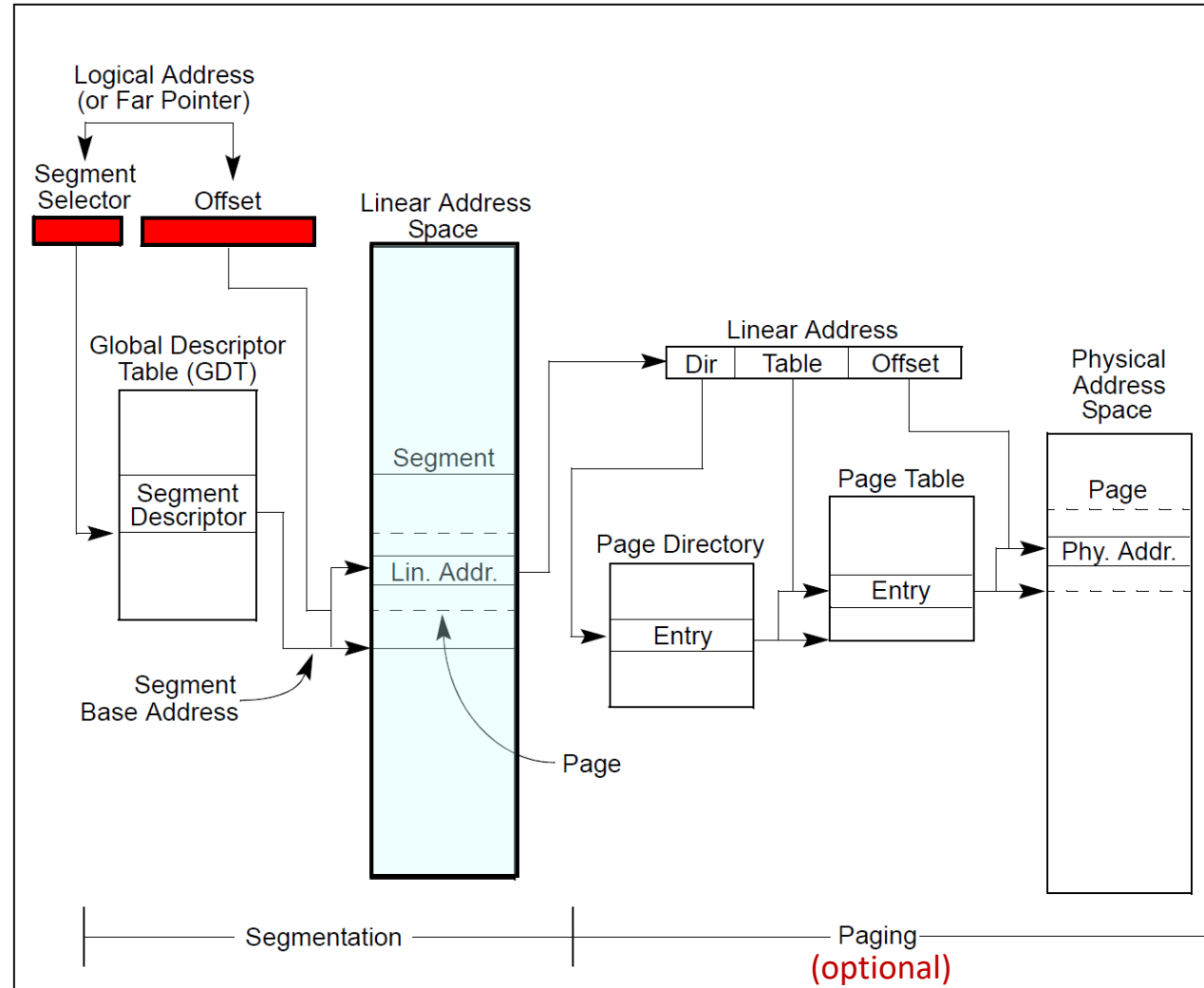

Multi-level Page Table: RISC-V

- Sv32 (used for RV32)

- 32-bit virtual address → 34-bit physical address

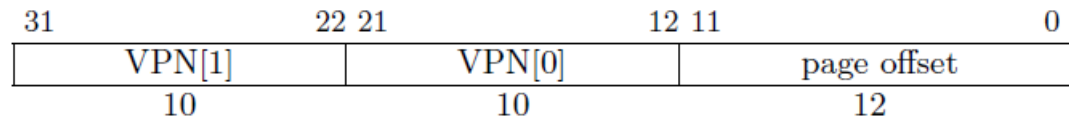

satp register holds the physical page number (PPN) of the root page table

- Sv39 (used in xv6)

- 39-bit virtual address → 56-bit physical address

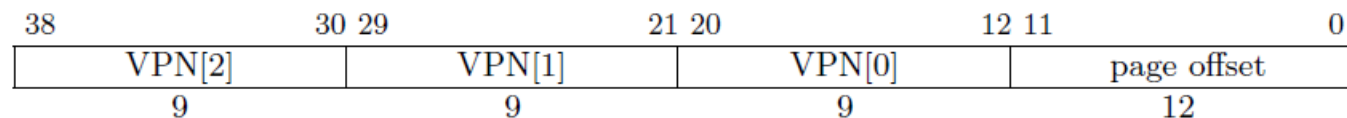

- Sv48

- 48-bit virtual address → 56-bit physical address

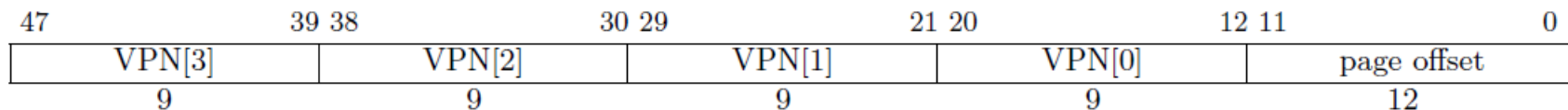

Summary: Multi-level Page Table

■ Pros

- Compact while supporting sparse address space
 - Page-table space in proportion to the amount of address space used
- Easier to manage physical memory
 - Each page table usually fits within a page
- Easier for hardware to walk through page tables
- No external fragmentation

■ Cons

- More memory accesses on a TLB miss
- More complex than a simple linear page-table lookup

Inverted Page Table

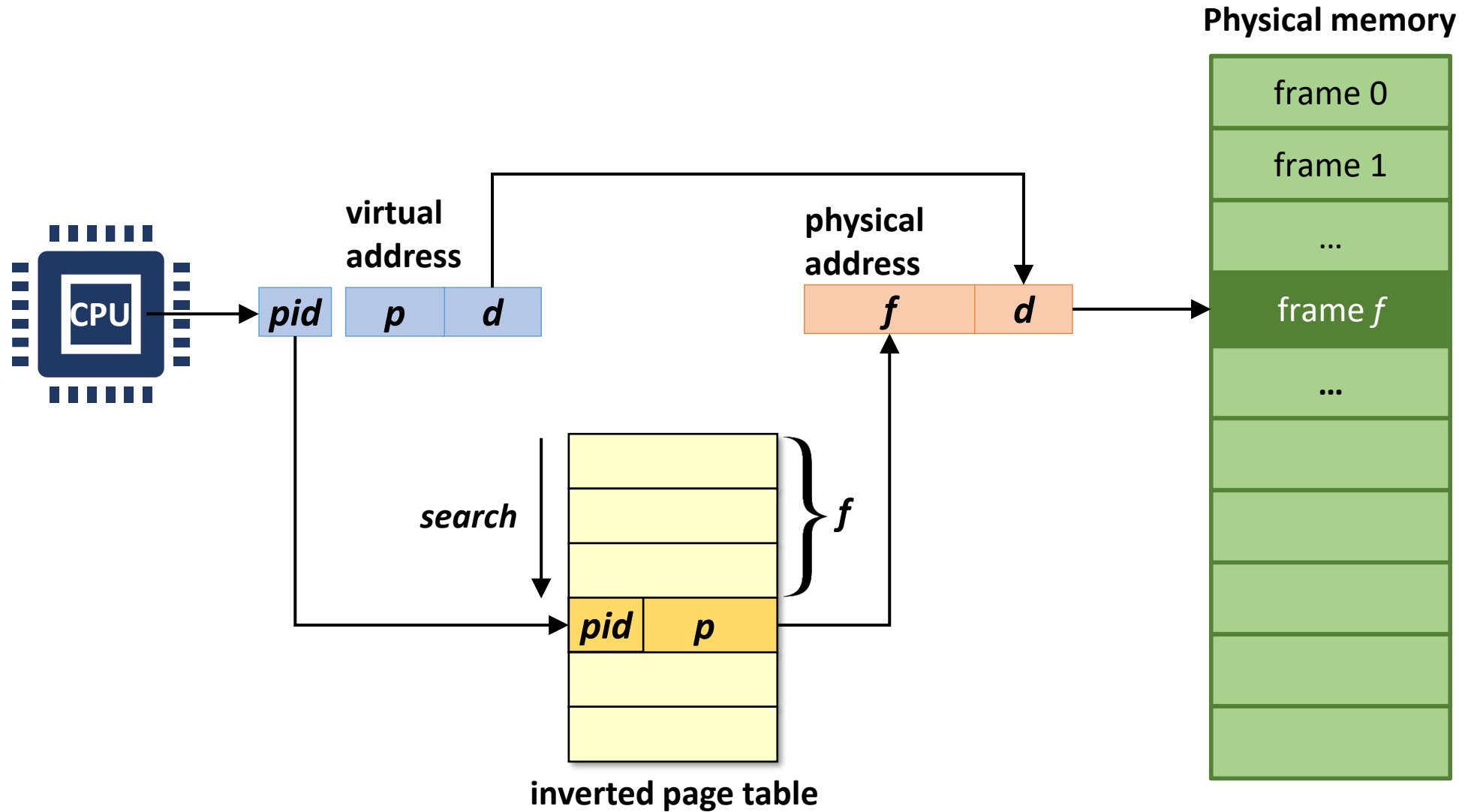

Summary: Inverted Page Table

- Reverse mapping from PFN \rightarrow \langle VPN, PID \rangle
 - One entry for each page frame in physical memory
 - Entry consists of the virtual page number with information about the process that owns that page
 - Need to search through the table to find match
 - Use hashing to limit the search to one, or at most a few, page-table entries
- Pros & Cons
 - Decrease memory needed to store page tables:
No need to have per-process page tables
 - Increase time needed to search the table on a TLB miss

Paging Page Tables

- Store page tables in _____ address space
 - Cold (unused) page table pages can be paged out to disk
 - But, now addressing page tables requires translation
 - Outer page table is usually pinned into physical memory
 - Outer page table points to the _____ addresses (in the kernel address space) of secondary page tables
 - Need to handle nested page faults
- What if we page kernel code and data too?