

Jin-Soo Kim  
([jinsoo.kim@snu.ac.kr](mailto:jinsoo.kim@snu.ac.kr))

Systems Software &  
Architecture Lab.

Seoul National University

Fall 2023

# Architectural Support for OS



# Computer System Organization

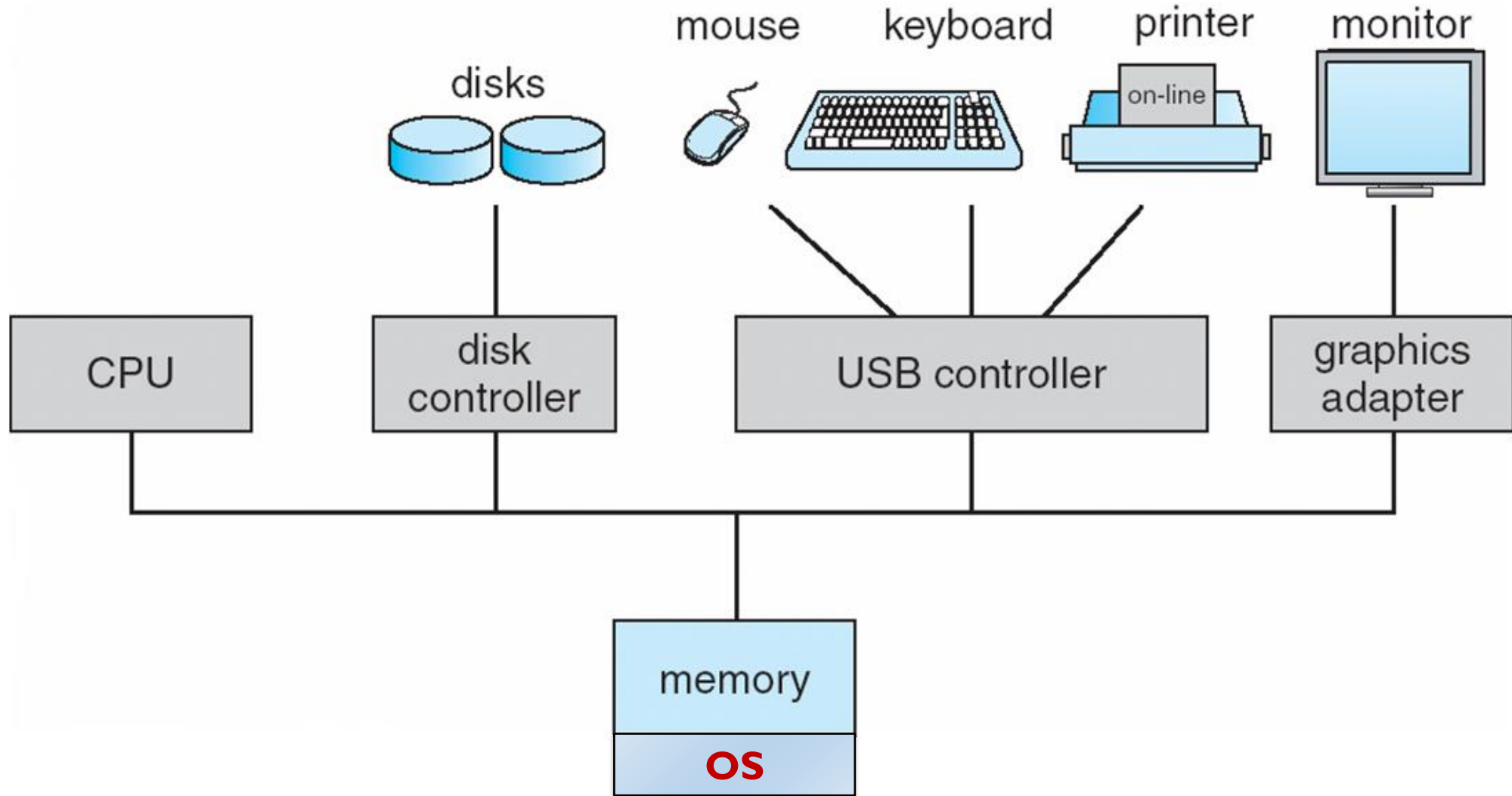

# Issue #1: I/O

- How to perform I/Os efficiently?

- I/O devices and CPU can execute concurrently
- Each device controller is in charge of a particular device type
- Each device has a local buffer
- CPU issues specific commands to I/O devices
- CPU moves data between main memory and local buffers

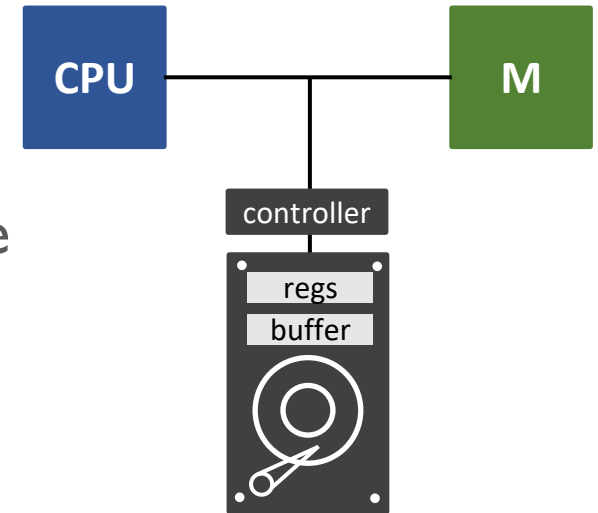

- CPU is a precious resource; it should be freed from time-consuming tasks

- Checking whether the issued command has been completed or not
- Moving data between main memory and device buffers

# Interrupts

- How does the kernel notice an I/O has finished?

- \_\_\_\_\_
- Hardware interrupt

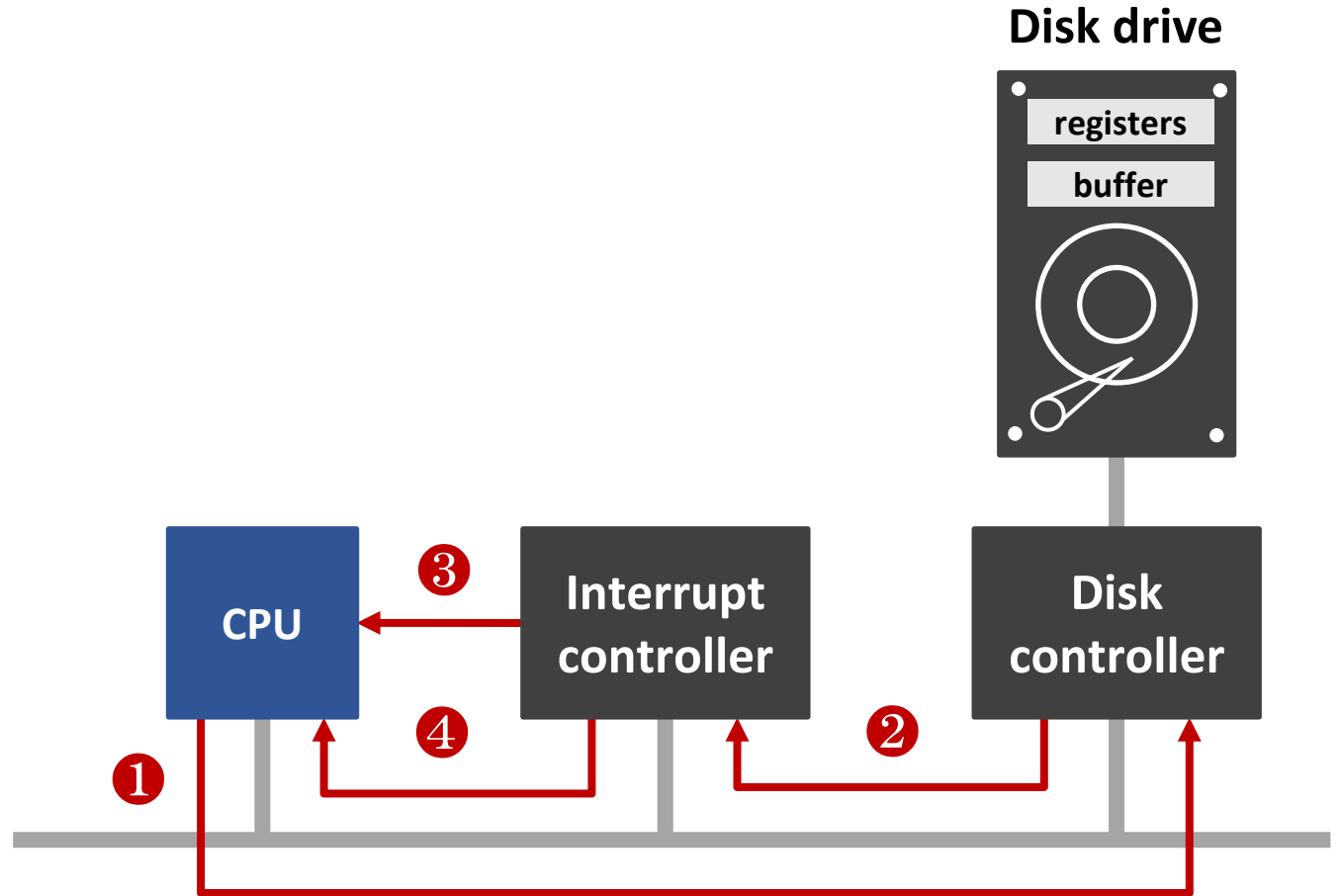
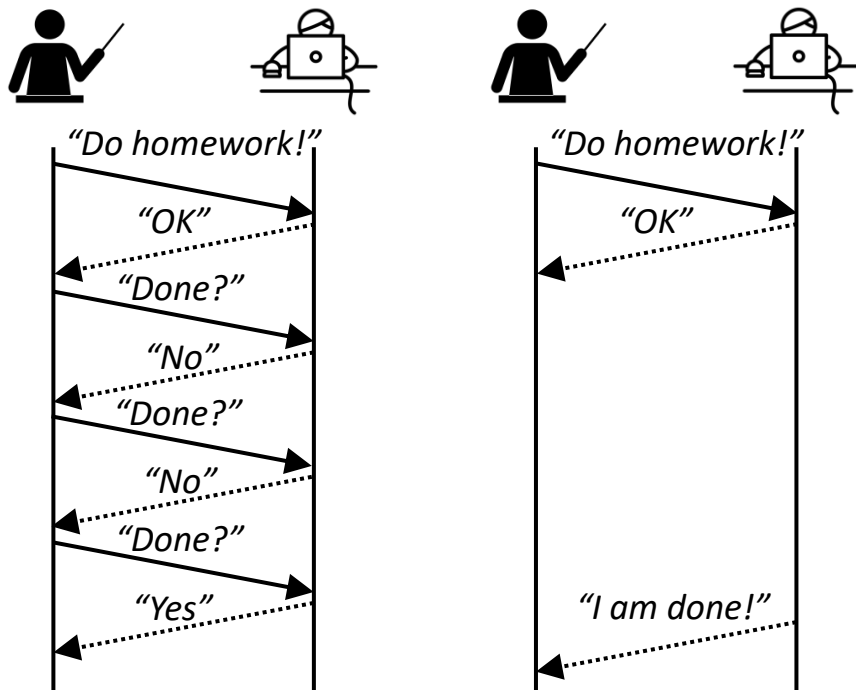

# Interrupt Handling

- Preserves the state of the CPU
  - In a fixed location
  - In a location indexed by the device ID
  - On the system stack
- Determines the type
  - Polling
  - Vectored interrupt system
- Transfers control to the interrupt service routine (ISR) or interrupt handler

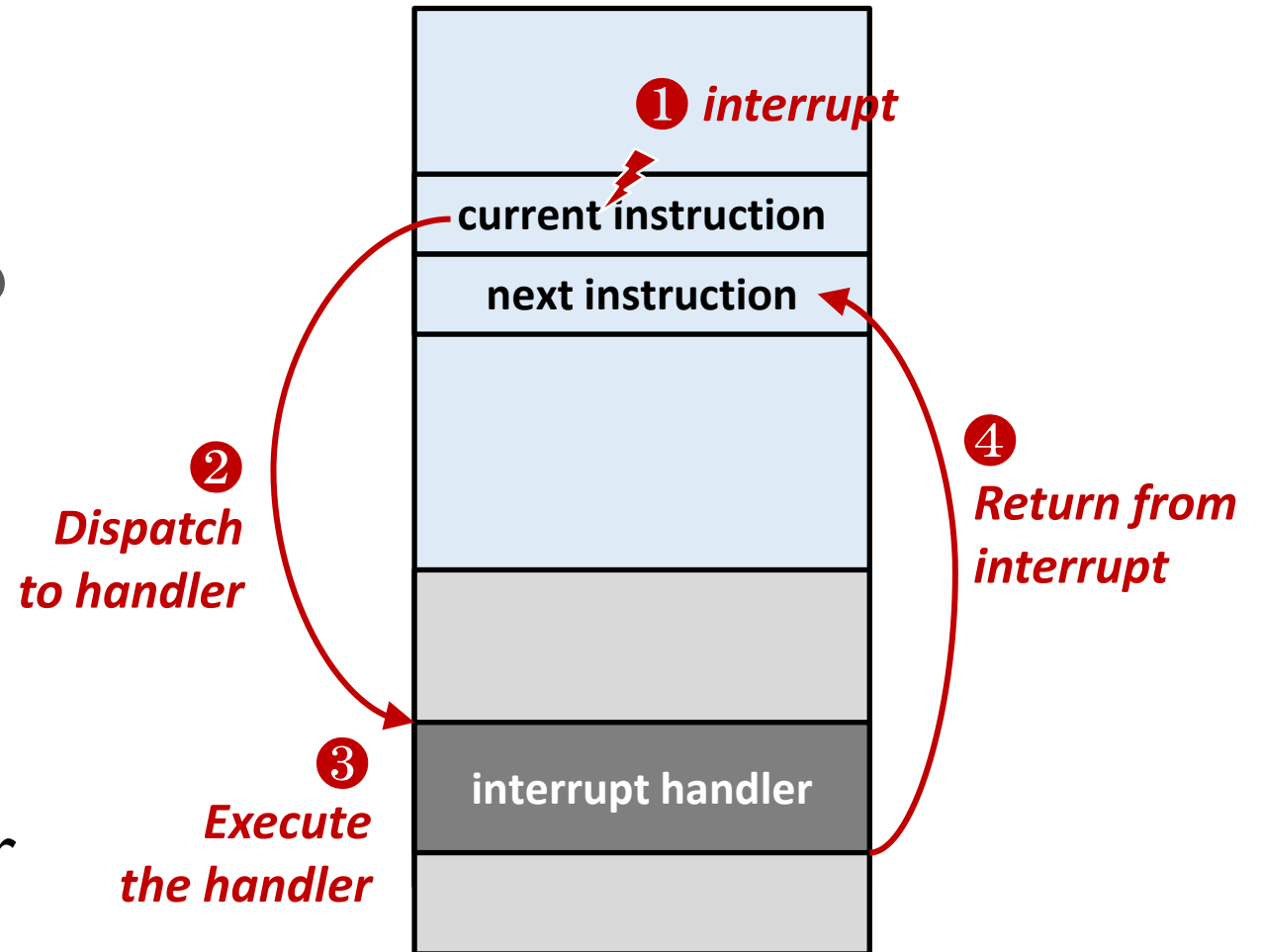

# Data Transfer Modes

- \_\_\_\_\_ (PIO)
  - CPU is involved in moving data between I/O devices and memory
  - By special I/O instructions vs. by memory-mapped I/O
  - e.g., keyboard, mouse, ...
- **DMA (Direct Memory Access)**
  - Used for high-speed I/O devices to transmit information at close to memory speeds
  - Device controller transfers blocks of data from the local buffer directly to main memory (or vice versa) without CPU intervention
  - Only an interrupt is generated per block
  - DMA controller oversees the overall data transfer

# Disk I/O Example

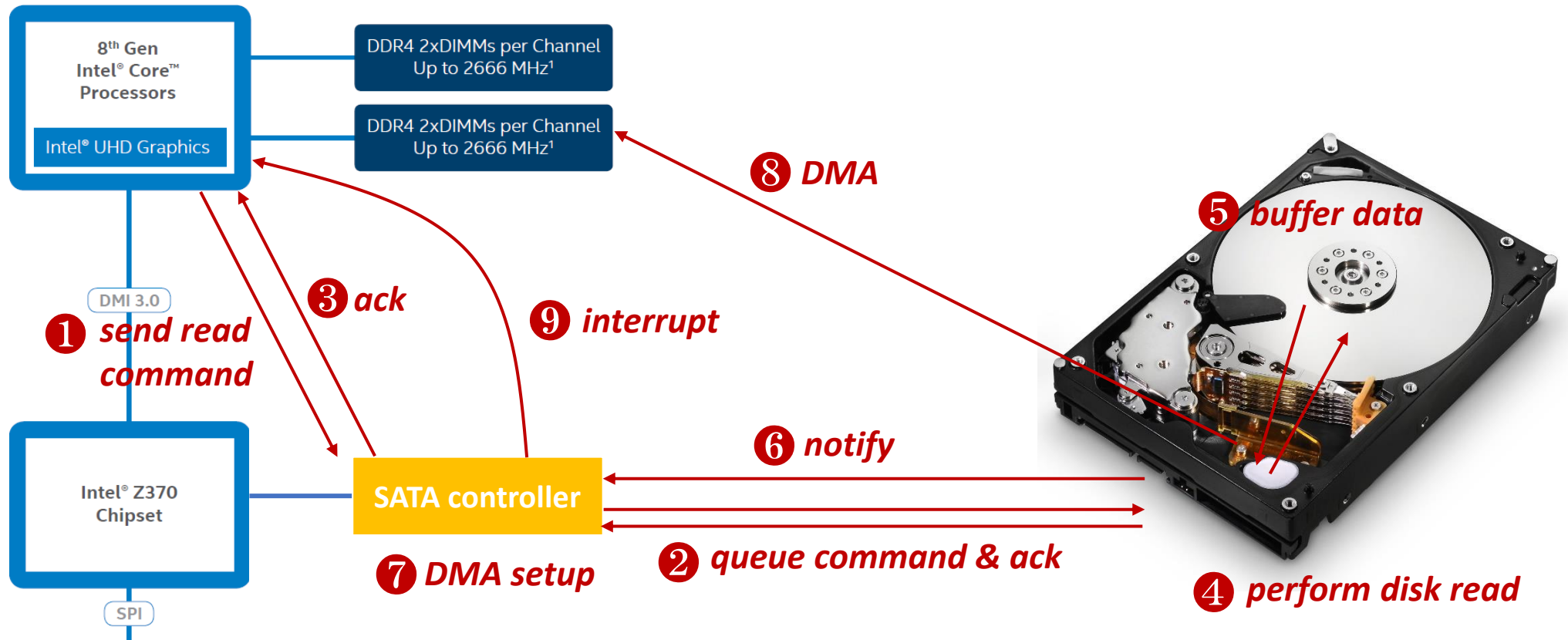

# Issue #2: Protection

- How to prevent user applications from harming the system?
  - What if an application accesses disk drives directly?
  - What if an application executes the HLT instruction?

## HLT—Halt

Opcode	Instruction	Op/ En	64-Bit Mode	Compat/ Leg Mode	Description
F4	HLT	NP	Valid	Valid	Halt

## Description

Stops instruction execution and places the processor in a HALT state.



# Protected Instructions

- Protected or \_\_\_\_\_ instructions
  - The ability to perform certain tasks that cannot be done from user mode
  - Direct I/O access
    - e.g., in / out instructions in x86
  - Accessing system registers
    - Control registers
    - System table locations (e.g., interrupt handler table)
    - Setting special “mode bits”, etc.
  - Memory state management
    - Page table updates, page table base address, TLB loads, etc.
  - HLT instruction in x86

# CPU Modes of Operation

## ■ Kernel mode vs. user mode

- How does the CPU know if a protected instruction can be executed?
- The architecture must support at least two modes of operation:  
**kernel** and **user** mode

- 4 privilege levels in x86\_64: Ring 0 > 1 > 2 > 3
- 4 privilege levels in ARM: EL3 > EL2 > EL1 > EL0
- 3 privilege levels in RISC-V: Machine > Supervisor > User
- Mode is set by a status bit in a protected register
  - IA-32: Current Privilege Level (CPL) in CS register
  - ARM: Mode field in CPSR register

## ■ Protected instructions can only be executed in the corresponding privileged level

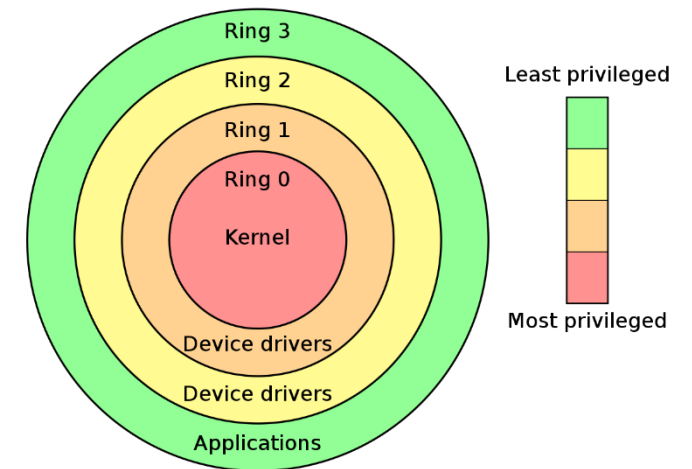

# Issue #3: Servicing Requests

- How to ask services to the OS?
  - How can an application read a file if it cannot access disk drives?
  - Even a “printf( )” call requires hardware access
  - User programs must ask the OS to do something privileged

# System Calls

- OS defines a set of system calls
  - Programming interface to the services provided by OS
  - OS protects the system by rejecting illegal requests
  - OS may impose a quota on a certain resource
  - OS may consider fairness while sharing a resource
- A system call is a \_\_\_\_\_ procedure call
  - System call routines are in the OS code
  - Executed in the kernel mode
  - On entry, user mode → kernel mode switch
  - On exit, CPU mode is changed back to the user mode

# System Calls Example

- POSIX vs. Win32

Category	POSIX	Win32	Description
Process Management	fork	CreateProcess	Create a new process (CreateProcess = fork + exec)
	waitpid	WaitForSingleObject	Wait for a process to exit
	execve	(none)	Execute a new program
	exit	ExitProcess	Terminate execution
	kill	(none)	Send a signal
File Management	open	CreateFile	Create a file or open an existing file
	close	CloseHandle	Close a file
	read	ReadFile	Read data from a file
	write	WriteFile	Write data to a file
	lseek	SetFilePointer	Move the file pointer
	stat	GetFileAttributesEx	Get various file attributes
	chmod	(none)	Change the file access permission
File System Management	mkdir	CreateDirectory	Create a new directory
	rmdir	RemoveDirectory	Remove an empty directory
	link	(none)	Make a link to a file
	unlink	DeleteFile	Destroy an existing file
	chdir	SetCurrentDirectory	Change the current working directory
	mount	(none)	Mount a file system

# Exceptional Events

## ■ Interrupts

- Generated by hardware devices
  - Triggered by a signal in INTR or NMI pins (x86\_64)
- Asynchronous

## ■ Exceptions

- Generated by software executing instructions
  - Unintentional: Divide-by-zero, ...
  - Intentional: **syscall** instruction in x86\_64 or **ecall** instruction in RISC-V
- Synchronous
- Exception handling is same as interrupt handling

# Exceptions in x86\_64

- \_\_\_\_\_
  - Intentional
  - System call traps, breakpoint traps, special instructions, ...
  - Return control to “next” instruction
- **Faults**
  - Unintentional but possibly recoverable
  - Page faults (recoverable), protection faults (unrecoverable), ...
  - Either re-executing faulting (“current”) instruction or abort
- \_\_\_\_\_
  - Unintentional and unrecoverable (parity error, machine check, ...)
  - Abort the current program

# OS Trap

- There must be a special “trap” instruction that:
  - Causes an exception, which invokes a kernel handler
  - Passes a parameter indicating which system call to invoke
  - Saves caller’s state (registers, mode bits)
  - Returns to user mode when done with restoring its state
  - OS must verify caller’s parameters (e.g., pointers)

## Examples:

**SYSCALL** instruction (x86\_64)

**ECALL** instruction (RISC-V)

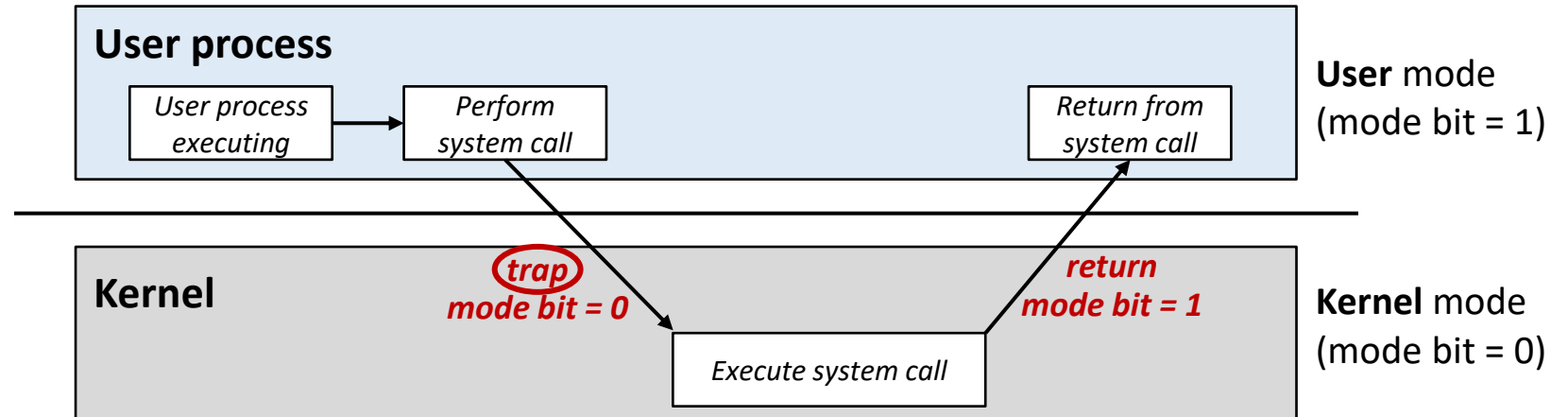



# Implementing System Calls

- `count = read(fd, buf, 512);`

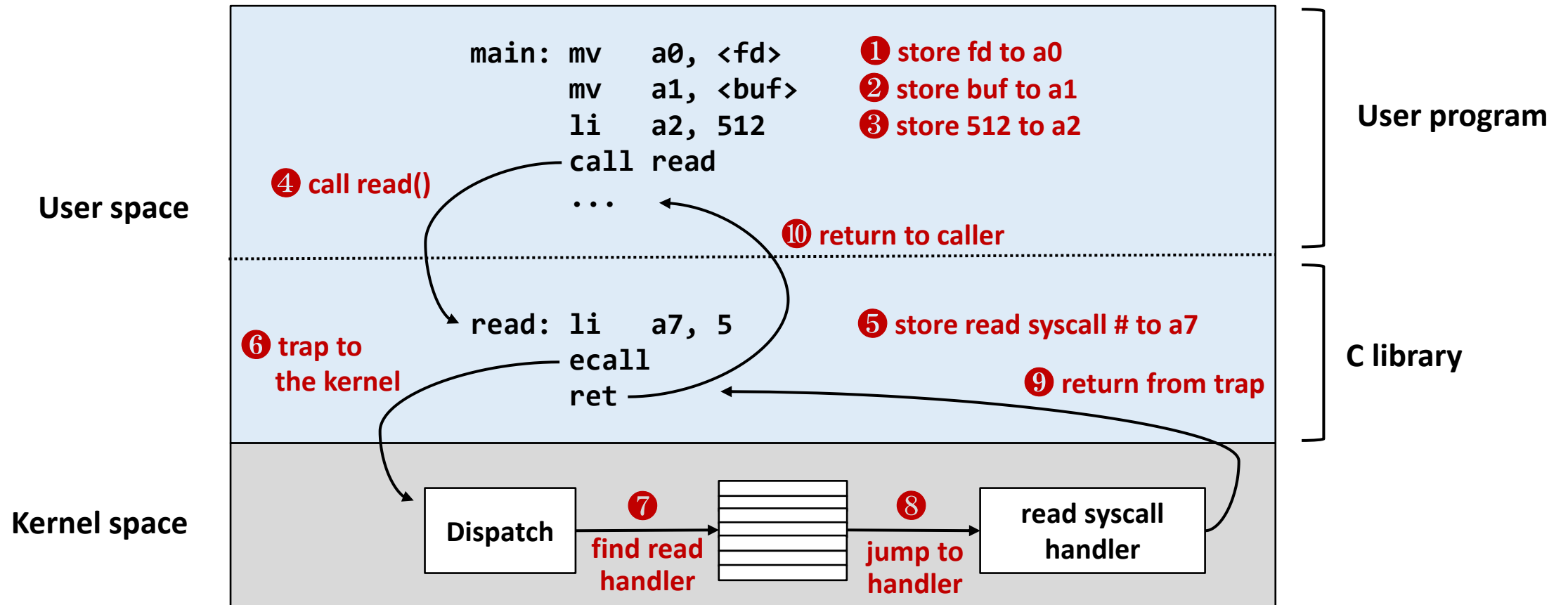

# Typical (Monolithic) OS Structure

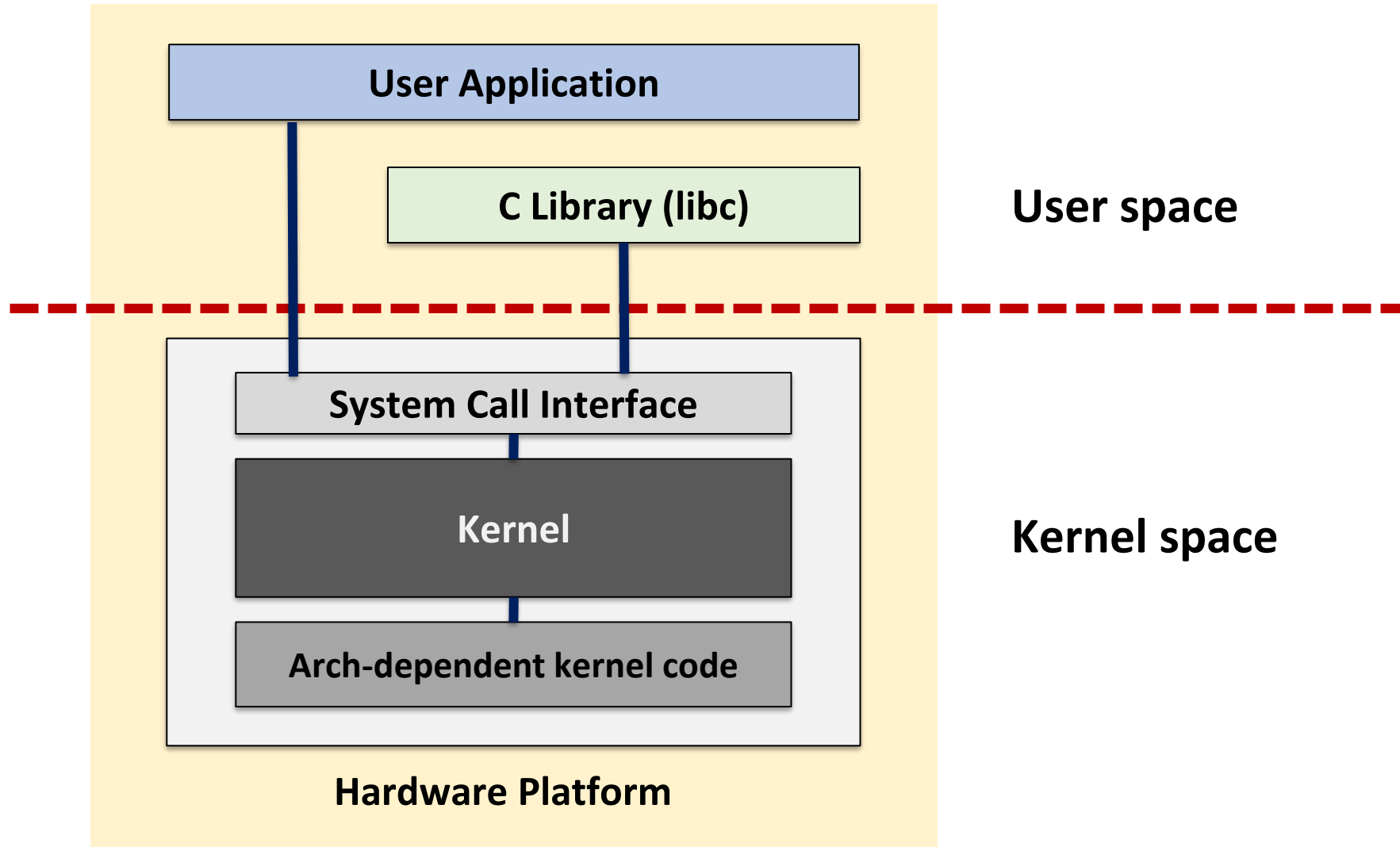

# Issue #4: Control

- How to take the control of the CPU back from the running program?
- Cooperative approach
  - Each application periodically transfers the control of the CPU to OS by calling various system calls
  - A special system call can be used just to release the CPU (e.g., `yield()`)
  - Can be used when \_\_\_\_\_
  - What if a process ends up in an infinite loop?  
(due to a bug or with a malicious intent)

# Timers

- A non-cooperative approach
  - Use a hardware timer that generates a periodic interrupt
  - The timer interrupt transfers control back to OS
- The OS preloads the timer with a time to interrupt
  - 10ms for Linux 2.4, 1ms for Linux 2.6, 4ms for Linux 5.5
  - 10ms for xv6
- The timer is privileged
  - Only the OS can load it

# Issue #5: Memory Protection

- How can we protect memory?
  - Unlike the other hardware resources, we allow applications to access memory directly without OS intervention. Why?
- From malicious users:  
OS must protect user applications from each other
- For integrity and security:  
OS must also protect itself from user applications

# Simplest Memory Protection

- Use base and limit registers
- Base and limit registers are loaded by OS before starting an application
- CPU generates an exception if the memory address is out of bound
- Can be used in a simple embedded environment

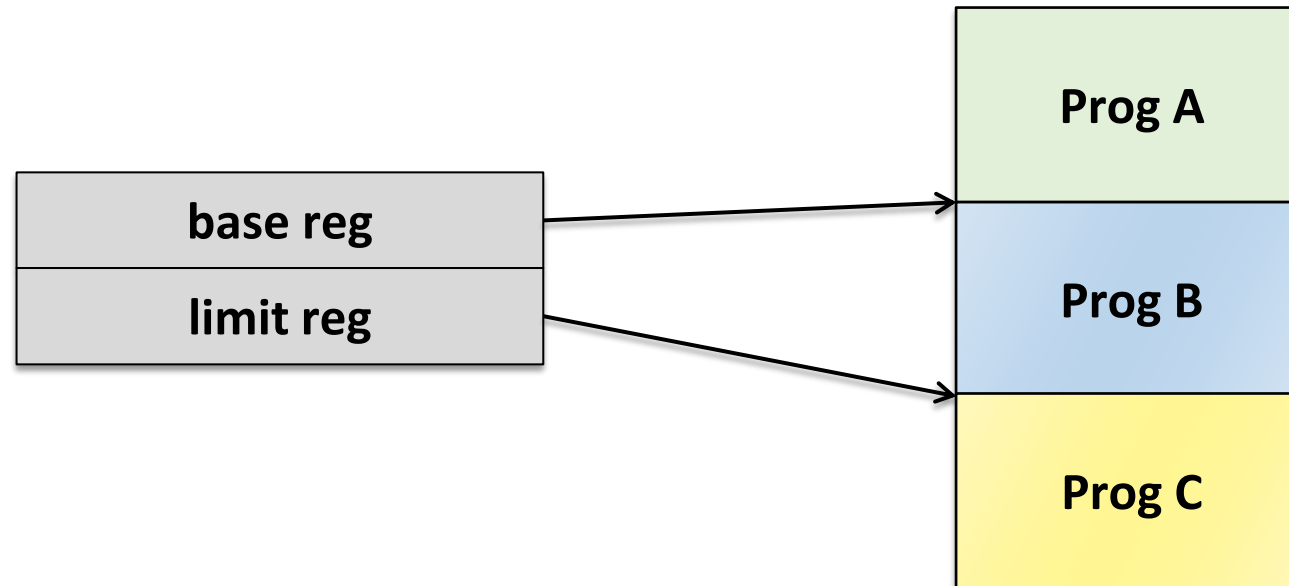

# Virtual Memory

- Modern CPUs are equipped with memory management hardware
  - MMU (Memory Management Unit)
- MMU provides more sophisticated memory protection mechanisms
  - Virtual memory
  - Paging: page tables, page protection, TLBs
  - Segmentation: segment tables, segment protection
- Manipulation of MMU is a privileged operation

# Issue #6: Synchronization

- How to coordinate concurrent activities?
  - What if multiple concurrent streams access the shared data?
  - Interrupt can occur at any time and may interfere with the interrupted code

```
LOAD R1 ← Mem[X]
```

```
ADD R1 ← R1, #1
```

```
LOAD R1 ← Mem[X]
```

```
ADD R1 ← R1, #1
```

```
STORE R1 → Mem[X]
```

```
STORE R1 → Mem[X]
```

- Turn off/on interrupts?



# Atomic Instructions

- **Requires special atomic instructions**
  - Read-Modify-Write (e.g., INC, DEC)
  - Test-and-Set
  - Compare-and-Swap
  - LOCK prefix in x86\_64
  - LL (Load Locked) & SC (Store Conditional) in MIPS
- **RISC-V “A” extension**
  - LR (Load Reserved) & SC (Store Conditional) instructions
  - AMO (Atomic Memory Operation) instructions
    - Swap, integer add, bitwise AND/OR/XOR, integer max/min (signed/unsigned)

# Summary

- The functionality of an OS is limited by architectural features
  - Multiprocessing on MS-DOS/8086?
- The structure of an OS can be simplified by architectural support
  - Interrupt, DMA, atomic instructions, etc.
- Most proprietary OSes were developed with the certain architecture in mind
  - SunOS/Solaris for SPARC
  - IBM AIX for Power/PowerPC
  - HP-UX for PA-RISC